



Instruction manual

TREE SHEAR

JAK-200B, JAK-250B, JAK-300B GEN4



Version: 1.03
Original instruction manual

TABLE OF CONTENTS

1 Revision history	5
2 General	6
2.1 About this manual	6
2.2 Product identification	6
2.3 Manufacturer	7
3 Safety	8
3.1 Safety symbols used in the manual	8
3.1.1 Warning symbols	8
3.1.2 Mandatory symbols	9
3.2 Safety signs on the product	9
3.3 Warnings and residual risks	11
3.3.1 Danger area	13
3.3.2 Use of personal protective equipment (PPE)	13
3.4 Noise emissions	13
3.5 Product limitations	13
3.5.1 Intended use and prohibited use	13
3.5.2 Base machine	14
3.5.3 Operating temperature	14
4 Overview	15
4.1 Main components	15
4.2 Technical data and dimensions	16
5 Installation	17
5.1 Transportation	17
5.1.1 Fastening instructions	18
5.2 Lifting	19
5.3 Storage	19
5.4 Commissioning	21
5.4.1 Welding the quick coupler	21
5.4.2 Connecting the hydraulics	21
5.4.3 Before first use	22
5.5 Dismounting the tree shear	23
6 Operation	25
6.1 Felling a tree	25
6.2 Loading timber	26
6.3 Operation in case of malfunction	27
7 Maintenance	28
7.1 Maintenance schedule, tree shear	28
7.2 Tightening torques	28
7.3 Maintenance instructions, tree shear	29

7.3.1	Checking the tightness of screws and nuts	29
7.3.2	Checking the tree shear for cracks or fractures	30
7.3.3	Checking the condition of the cutting blade	30
7.3.4	Checking for hydraulic leaks	31
7.3.5	Greasing the tree shear	31
7.3.6	Cleaning the tree shear	32
7.3.7	Sharpening the cutting blade	33
7.3.8	Replacing the cutting blade	33
7.3.9	Replacing the hydraulic hose and connector	34
7.4	Spare parts and maintenance contacts	35
8	Options	36
8.1	Optional equipment available	36
8.2	Collector unit	36
8.2.1	Overview	36
8.2.1.1	Product identification	37
8.2.2	Installation	38
8.2.2.1	Lifting the collector unit	38
8.2.2.2	Installing the collector unit	38
8.2.3	Operation	39
8.2.3.1	Operating the collector unit	39
8.2.4	Daily maintenance	42
8.2.4.1	Greasing	42
8.2.4.2	Cleaning the collector unit	42
8.2.4.3	Checking the collector unit	43
8.3	Guillotine unit	43
8.3.1	Overview	43
8.3.2	Product identification	43
8.3.3	Installation	45
8.3.3.1	Lifting the guillotine unit	45
8.3.3.2	Installing the guillotine unit	45
8.3.4	Maintenance	46
8.3.4.1	Daily maintenance	46
8.3.4.1.1	Greasing the guillotine unit	46
8.3.4.1.2	Checking the guillotine unit	47
8.3.4.1.3	Cleaning the guillotine unit	48
8.3.4.2	Replacing the guillotine blades	48
8.4	Felling support	50
8.4.1	Overview	50
8.4.2	Installation	50
8.4.3	Daily maintenance	51
8.5	Foot	51
8.5.1	Overview	51

Table of contents

8.5.2 Installation	52
8.6 Solid extension	52
8.6.1 Overview	52
8.6.2 Installation	53
8.6.2.1 Lifting the solid extension	53
8.6.2.2 Installing the solid extension	53
8.6.3 Daily maintenance	54
9 Attachments	55

1 REVISION HISTORY

Revision	Date	Description	Author
1.00	12.12.2022	Document created	JH
1.01	27.3.2023	Changes: <ul style="list-style-type: none"> • Added revision history • Cover picture updated • JAK-300B base machine weight updated • Safety distance warning sign images updated in chapter Safety signs on the product • Updated image in chapter Transportation • Updated text in chapter Operation on case of malfunction • Added Product identification to chapter Collector unit • Added warranty clause 	JH
1.02	22.11.2023	Changes: <ul style="list-style-type: none"> • Solid extension added to optional equipment • Collector unit operation section added 	LN
1.03	25.10.2024	Changes: <ul style="list-style-type: none"> • Updated to tree shear GEN4 • Updated the collector unit to GEN2 • Added instructions for the guillotine unit • Added instructions for the foot • Updated instructions for the felling support • Removed instructions for the tilting unit 	MH

2 GENERAL

2.1 About this manual

The purpose of this Instruction manual is to promote safe, proper and optimal use and maintenance of the tree shear. The manual also helps to identify, avoid and prevent hazardous situations and related consequences.

This Instruction manual is intended for the final user. If this manual is lost, damaged or becomes unreadable, contact your local dealer for a replacement copy.



Read and understand the manual carefully. Follow the given instructions. Follow the instructions in local laws and regulations and any orders given by local authorities.

This Instruction manual covers the tree shear models JAK-200B, JAK-250B and JAK-300B.

2.2 Product identification

The tree shear has a manufacturer's plate (1) behind the buffer plate.

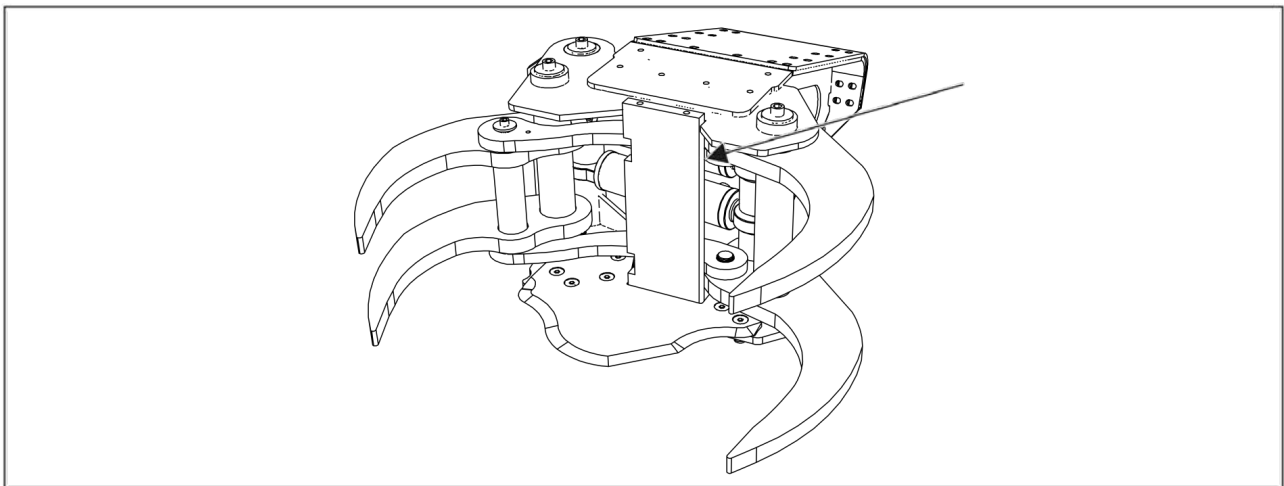

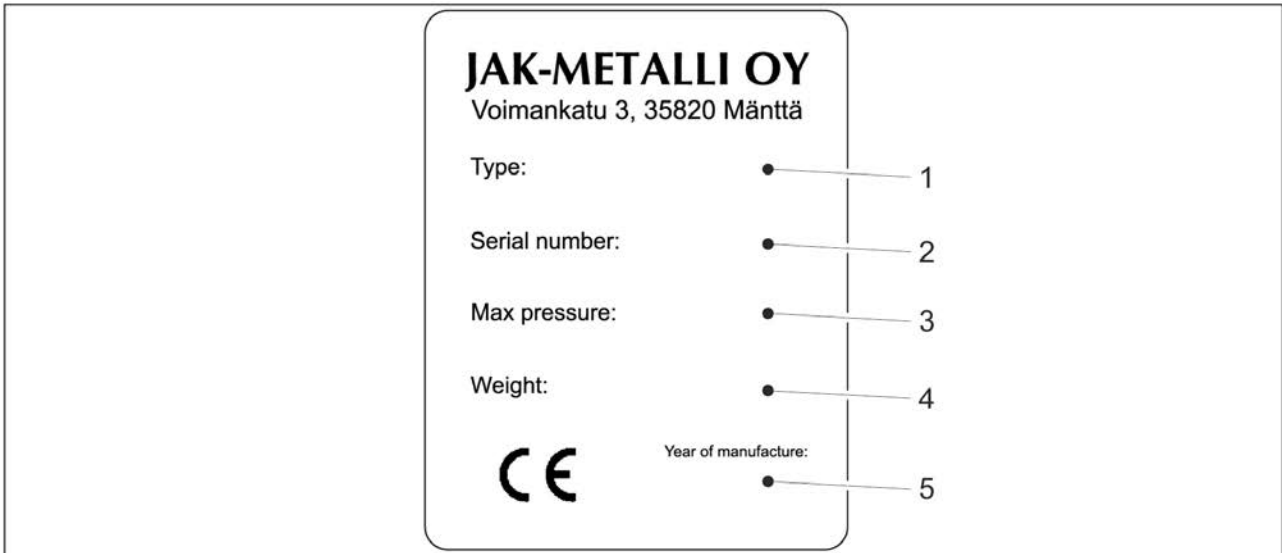

Location	Information
1	Type
2	Serial number
3	Maximum pressure
4	Weight
5	Year of manufacture



2.3 Manufacturer

JAK-Metalli Oy
Voimankatu 3
35820 Mänttä
Finland





Telephone: +358 40 080 4658
Email: info@jak.fi
Web: www.jak.fi

3 SAFETY



3.1 Safety symbols used in the manual

	DANGER indicates a potentially dangerous situation that can cause death or serious injury.
	WARNING indicates a potentially hazardous situation that can cause property damage.
	NOTE contains helpful tips, advice and other useful information.

3.1.1 Warning symbols



	HANGING LOAD indicates a load that can fall and cause injuries.
	SHARP ELEMENT indicates a sharp object that can cause injuries by cuts.
	CRUSHING HAZARD indicates a situation where a person can get crushed by moving objects.
	ELECTRICAL HAZARD indicates a situation where a person can receive injuries from open electric sources.
	LIFTING HAZARD indicates a situation where lifting a heavy item can cause injuries.

3.1.2 Mandatory symbols

	<p>INSTRUCTION MANUAL</p>
	<p>EYE PROTECTION</p>
	<p>PROTECTIVE GLOVES</p>
	<p>Refer to instruction manual.</p> <p>Wear protective eye wear such as safety goggles.</p> <p>Wear protective gloves.</p>

3.2 Safety signs on the product

The tree shear has two safety signs.

1		<p>Obey the safety distance.</p>
2		<p>Read the manual.</p>

The location of the safety signs:

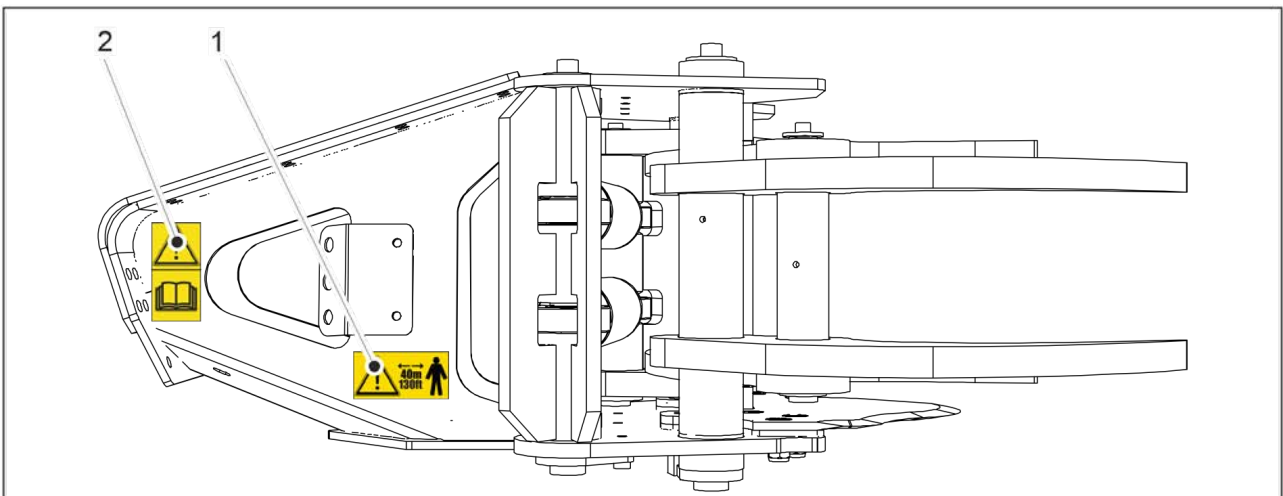

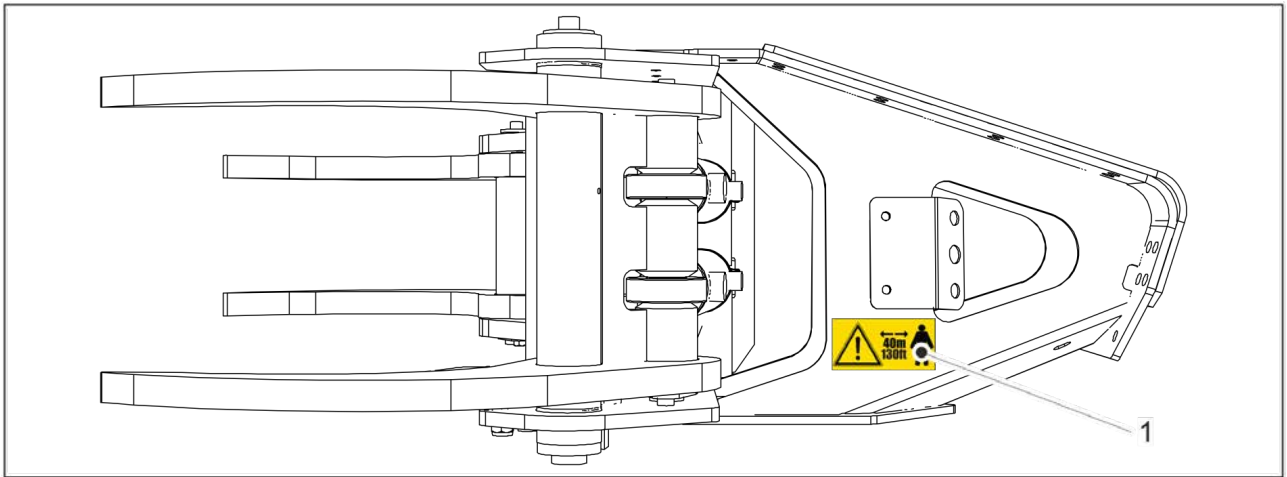







3.3 Warnings and residual risks

	<p>DANGER</p> <p>Hanging load hazard</p> <p>The tree shear or its load can fall when lifted and cause injuries or even death.</p> <p>Do not stand underneath the tree shear.</p>
---	--



	<p>DANGER</p> <p>Crushing hazard</p> <p>Moving parts can cause injuries or even death.</p> <p>Observe caution near the tree shear when the hydraulic lines are connected. Do not put your hands inside the tree shear when the hydraulic lines are connected.</p>
---	---

	<p>DANGER</p> <p>Sharp blade hazard</p> <p>The blade can cause injuries and cuts.</p> <p>Observe caution when near the blade. Wear protective goggles and gloves when you sharpen the blade.</p>
	
	

	<p>DANGER</p> <p>Sharp blade hazard</p> <p>The blade can cause injuries and cuts.</p> <p>Observe caution when near the blade. Wear protective gloves when you handle the blade.</p>
	

	<p>DANGER</p> <p>Electricity hazard</p> <p>Current from electric lines can cause injuries or even death.</p> <p>Observe caution when you use the tree shear near electric lines.</p>
---	--

	<p>DANGER</p> <p>Unstable machinery hazard</p> <p>Handling of oversized trees with the tree shear can change the balance of the machine cause it to fall over.</p> <p>Cut and handle large trees in segments with the tree shear. Grab large trees from the middle point.</p>
---	---

	<p>DANGER</p> <p>Hydraulic fluid</p> <p>High pressure hydraulic fluid can cause injury or even death.</p> <p>Relieve the hydraulic pressure before maintenance. Wear protective gloves and goggles when handling hydraulic fluid.</p>
	
	

	<p>DANGER</p> <p>Lifting hazard</p> <p>The unit is heavy and can cause injuries if lifted.</p> <p>Do not lift the unit on your own. Use a lifting aid.</p>
---	--

	<p>WARNING</p> <p>Damage to equipment</p> <p>Poor welding can break and cause the tree shear to fall down.</p> <p>Leave welding work for professionals. Follow local requirements and standards. The manufacturer is not responsible for the durability of welds done on the coupler by other parties.</p>
---	--

3.3.1 Danger area

The danger area is 40 m around the tree shear. Ensure that no one enters this area during operation.

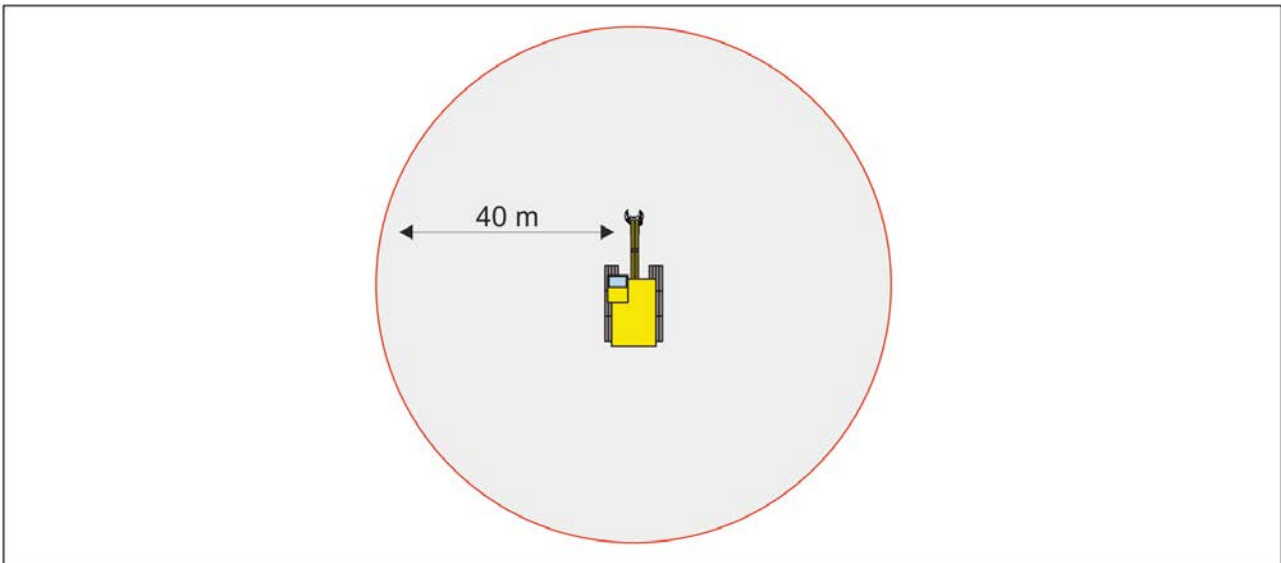

3.3.2 Use of personal protective equipment (PPE)



NOTE

Wear protective goggles when you sharpen the blade and when you work with hydraulic lines.



NOTE

Wear protective gloves when you sharpen or handle the blade and when you work with hydraulic lines.

3.4 Noise emissions

The A-weighted emission sound pressure level of the tree shear is 68 dB (<70 dB), measured at 1 m distance during operation.

3.5 Product limitations

3.5.1 Intended use and prohibited use

Intended use

The tree shear is intended for efficient cutting and loading trees. It is used for clearing trees and bushes along roads, electrical lines and ditches, as well as in parks and near houses. The model designation indicates the maximum cutting width of the tree shear.

The tree shear has two hydraulically controlled jaws that can be opened and closed. When the cutting blade is attached the tree shear is used for cutting and stacking trees. When the blade is removed the tree shear can be used for loading timber.

Prohibited use

Do not use the tree shear for handling any other materials than timber.

Do not cut trees that are thicker than specified for the tree shear model.

Do not modify the tree shear in any way not specified by the manufacturer such as welding, cutting or drilling holes to it.



NOTE

Prohibited use voids the warranty of the tree shear.

3.5.2 Base machine

The B-model tree shears are intended for excavators of different weight classes.

3.5.3 Operating temperature

It is not recommended to use the tree shear in temperatures under -15 °Celsius. Colder temperatures can cause metal fatigue on the tree shear.

4 OVERVIEW

4.1 Main components

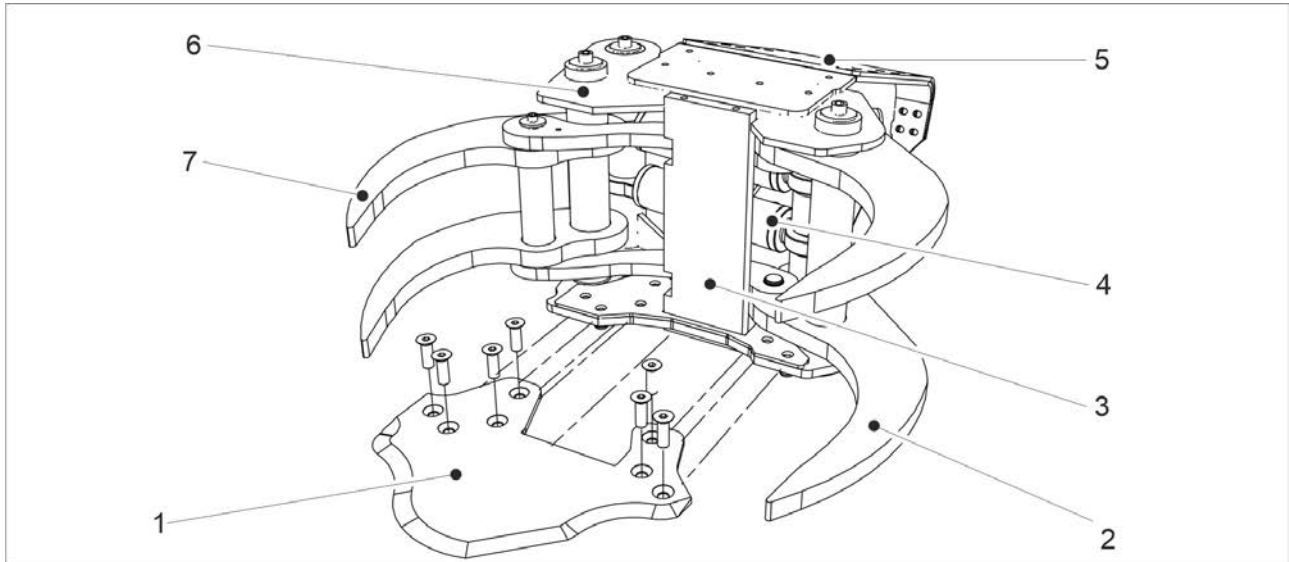

1.	Cutting blade
2.	Cutting side jaw
3.	Buffer plate
4.	Hydraulic cylinders
5.	Adapter plate
6.	Main body
7.	Assisting side jaw

4.2 Technical data and dimensions

Product name	JAK-200B	JAK-250B	JAK-300B
Excavator weight	1,8-5 ton kg (4000-11000 lbs)	5-12 ton kg (11000-26455 lbs)	12-20 ton kg (26455-44092 lbs)
Weight	160 kg (352,7 lbs)	290 kg (639,3 lbs)	590 kg (1300 lbs)
Cutting diameter	200 mm (7,9 in)	250 mm (9,8 in)	300 mm (11,8 in)
Operating pressure	200-300 bar (2900-4351 psi)	250-300 bar (3625-4351 psi)	250-300 bar (3625-4351 psi)
Minimum oil flow	30 l/min (7,9 gal/min)	50 l/min (13,2 gal/min)	60 l/min (15,8 gal/min)
Width when open	600 mm (23,6 in)	690 mm (27,1 in)	840 mm (33 in)
Buffer plate height	310 mm (12 in)	390 mm (15,3 in)	505 mm (19,8 in)

5 INSTALLATION

5.1 Transportation

Transport the tree shear in horizontal position. During transportation the jaws must be closed so that the cutting blade is covered by the jaws.

Fasten the tree shear to the transportation baseplate with cargo straps. To select suitable cargo straps, consider that:

- The tree shear has sharp edges. Use coated cargo straps.
 - The tree shear and attached optional equipment are heavy. Make sure the cargo straps withstand the weight.
-



NOTE

Make sure the cargo straps cannot damage the hydraulic lines during transportation.

5.1.1 Fastening instructions

1. Tie the tree shear to the baseplate:
 - o From behind the buffer plate (2) with cargo straps (1).

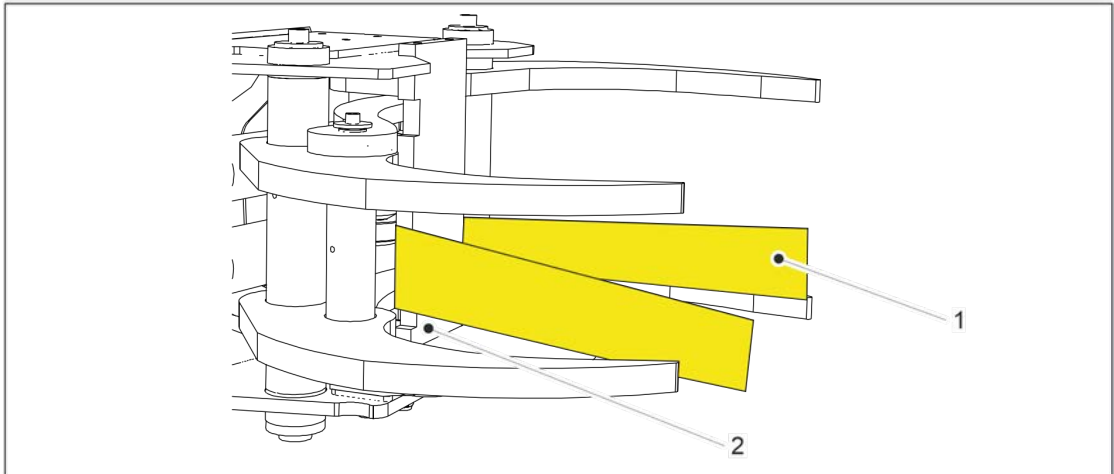

- o Through the back opening with a cargo strap (1).

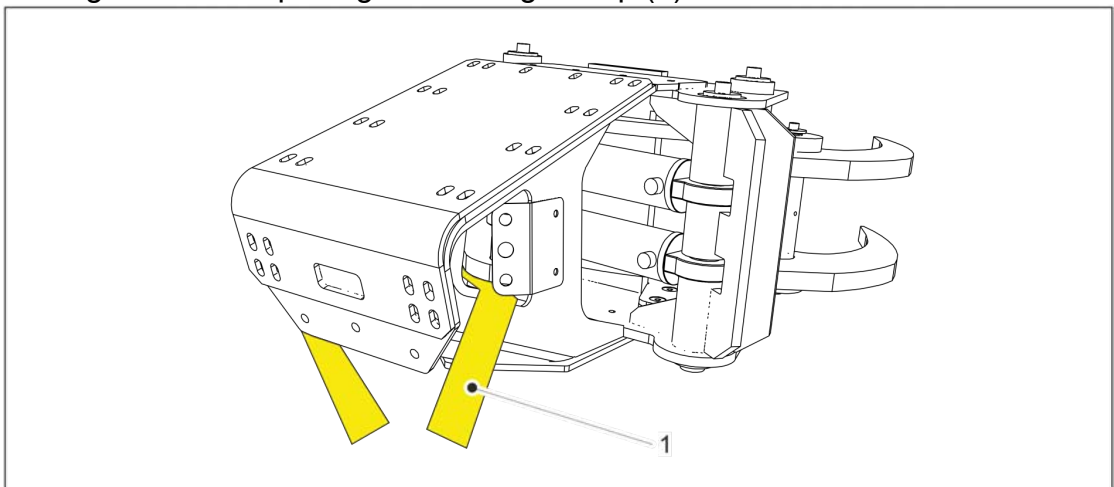

5.2 Lifting



DANGER

Hanging load hazard

The tree shear or its load can fall when lifted and cause injuries or even death. Do not stand underneath the tree shear.



NOTE

Make sure that the lifting belt or chain cannot damage the hydraulic lines during lifting.

During lifting the jaws must be closed so that the cutting blade is covered by the jaws.

Lift the tree shear with a lifting belt or chain. To select a suitable lifting belt or chain, consider that:

- The tree shear has sharp edges.
- The tree shear and attached optional equipment are heavy. Make sure the lifting belt or chain can withstand the weight.

Run a lifting belt (1) or chain through the opening in the middle. The tree shear remains balanced when lifted from the middle opening.

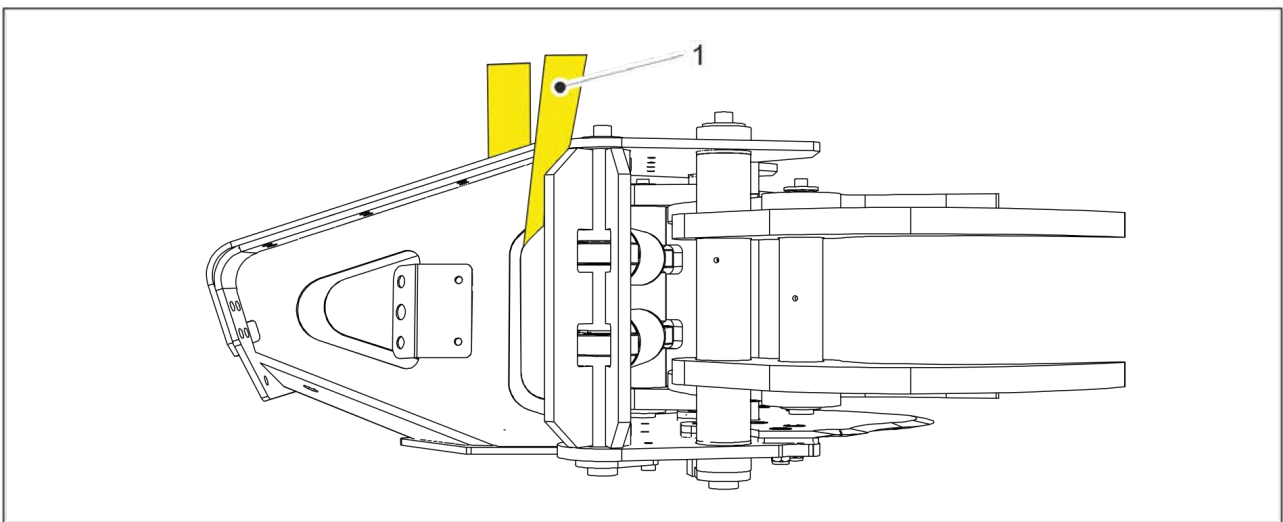

5.3 Storage

Before storage:

- Wash the tree shear with a pressure washer.
- Apply grease to the grease nipples.

Storage conditions:

- Store the tree shear indoors when possible.
- If the tree shear is stored outdoors, cover it with a waterproof tarpaulin.
- Close the hydraulic lines with caps.

Storage position:

- Store the tree shear on a stable flat surface.
- For safety reasons, close the jaw to ensure the blade is covered by the jaws.
-

Long-term storage:

- Check that there is grease in the grease nipples at least once per year.
- If the tree shear is taken into use after a long storage period, perform the before first use checks again. See chapter [5.4.3 Before first use](#).

5.4 Commissioning

5.4.1 Welding the quick coupler

The tree shears can be equipped with common excavator quick couplers. Couplers are also available according to order.

If the tree shear is delivered without a quick coupler, obey the following precaution for welding the quick coupler.

	<p>WARNING</p> <p>Damage to equipment</p> <p>Poor welding can break and cause the tree shear to fall down. Leave welding work to professionals. Follow local requirements and standards. The manufacturer is not responsible for the durability of welds done on the coupler by other parties.</p>
---	--

	<p>NOTE</p> <p>Do not modify the tree shear in any way not specified by the manufacturer such as welding, cutting or drilling holes to it.</p>
--	---

5.4.2 Connecting the hydraulics

	<p>DANGER</p> <p>Crushing hazard</p> <p>Moving parts in the tree shear can cause injuries or even death. Observe caution near the tree shear when the hydraulic lines are connected. Do not put your hands inside the tree shear when the hydraulic lines are connected.</p>
---	--

Tree shear	Hydraulic connector
JAK-200B	R 3/8"
JAK-250B	R 1/2"
JAK-300B	R 3/4"

1. Ensure that the hydraulic lines in the base machine are pressure free. For safe work methods, see the instruction manual of the base machine.

2. Connect the inflow and outflow (1) hydraulic lines.

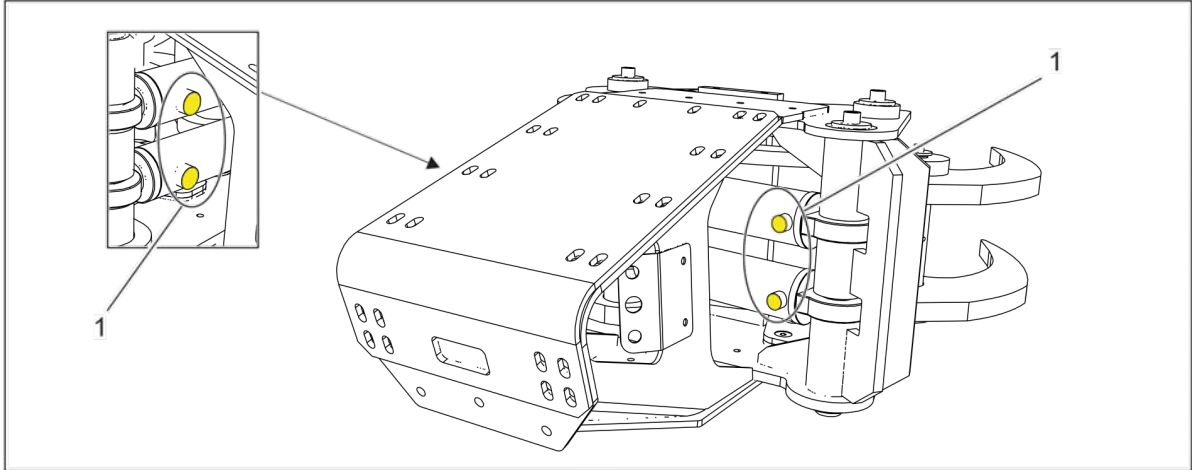

3. Open and close the jaws to ensure that the hydraulic lines are connected in the intended order.
4. Measure the hydraulic pressure before using the tree shear. Target pressure is the maximum pressure of the tree shear model. The opening and closing speed of the jaws is dependent on the hydraulic oil flow of the base machine.

5.4.3 Before first use

1. If you installed the excavator adapter, check the tightness of the quick coupler bolts and nuts (1-10). The quantity of the bolts and nuts varies according to the tree shear size.

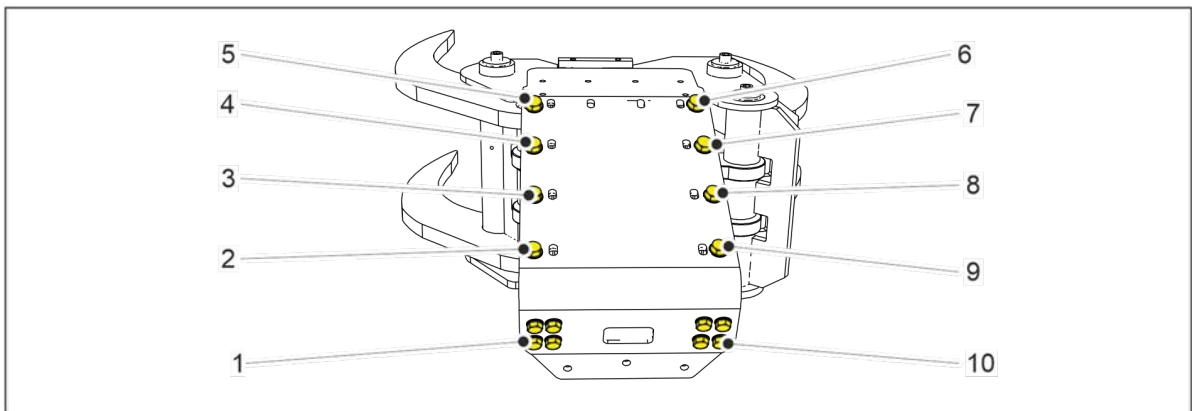

2. Check the tightness of the top bolts (1-4).

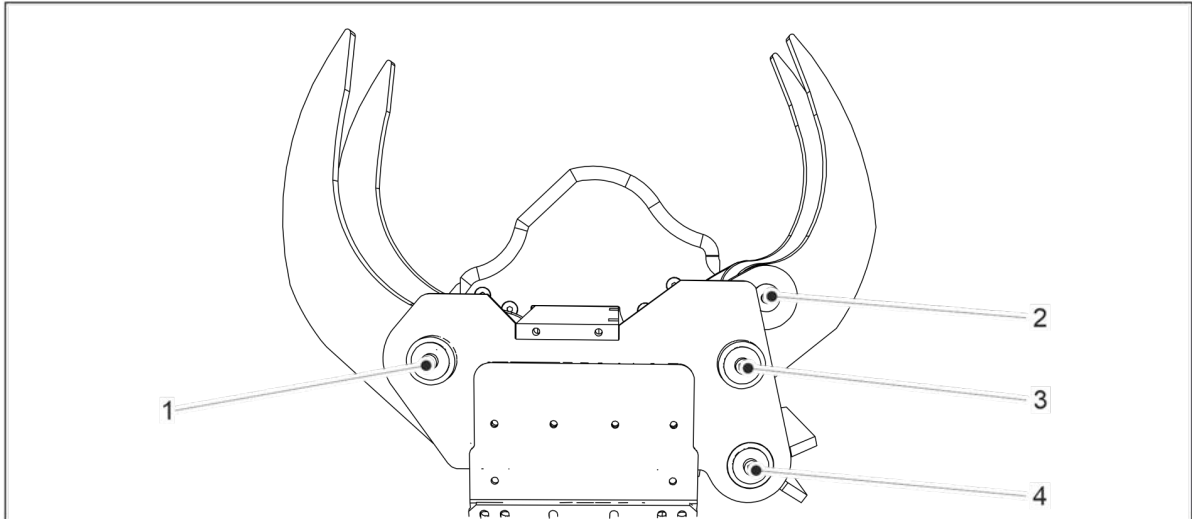

3. Check the tightness of the cutting blade bolts (1-7).

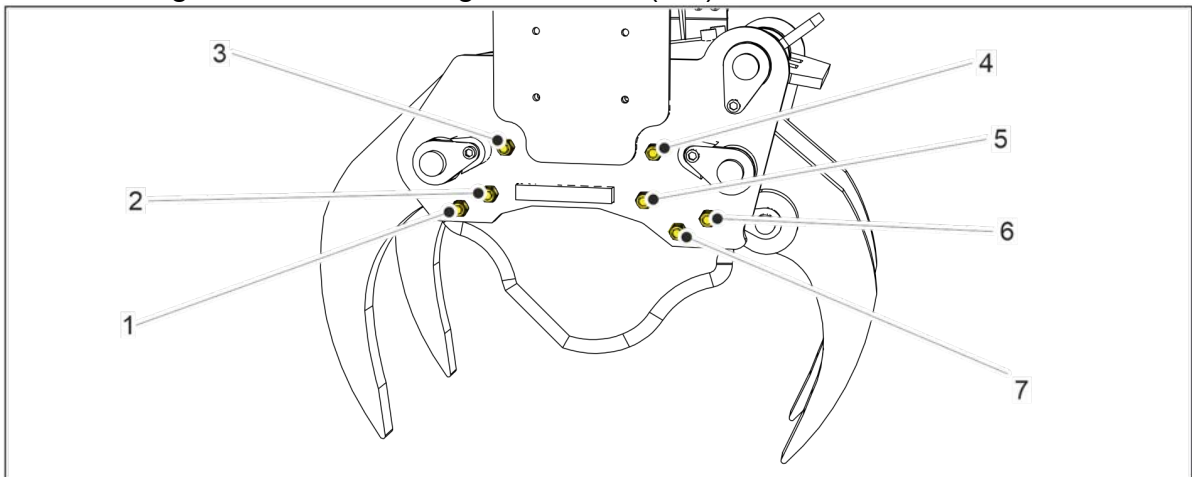

4. Check the tightness of the bottom bolts (1-3).

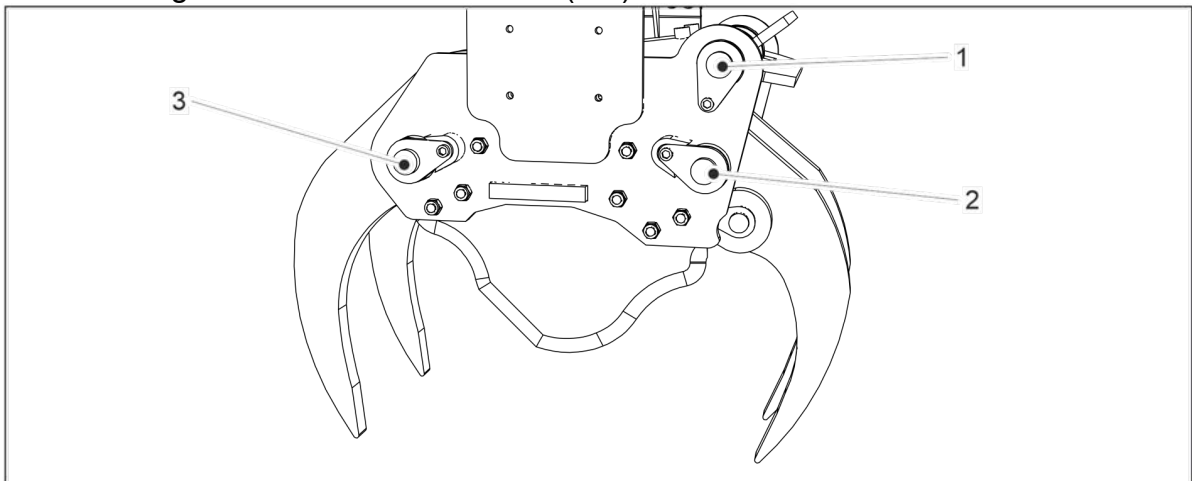

5. Apply grease to the grease nipples. See section [7.3.5 Greasing the tree shear](#)

5.5 Dismounting the tree shear

1. Close the jaws almost shut so that the cutting blade is covered by the jaws.
2. Lower the tree shear to the ground or transportation vehicle.

3. Relieve pressure from the hydraulic lines. For safe work methods, see the instruction manual of the base machine.

**NOTE**

Oil can leak from the hydraulic lines when they are detached.

4. Detach the hydraulic lines. Close the hydraulic lines with caps.
5. Detach the quick coupler from the base machines.

6 OPERATION

6.1 Felling a tree

	<p>DANGER</p> <p>Falling tree hazard</p> <p>Felled tree can cause damage, injuries or even death if it hits objects or people.</p> <p>Always fell the tree in direction away from the base machine and buildings.</p>
---	---

	<p>DANGER</p> <p>Electricity hazard</p> <p>Current from electric lines can cause injuries or even death. Observe caution when you use the tree shear near electric lines.</p>
---	---

	<p>DANGER</p> <p>Unstable machinery hazard</p> <p>Handling of oversized trees with the tree shear can change the balance of the machine and cause it to fall over.</p> <p>Cut and handle large trees in segments with the tree shear. Grab large trees from the middle point.</p>
--	---

	<p>NOTE</p> <p>If the wood is hard or the hydraulic pressure is low, it is possible that the tree shear cannot cut a tree of maximum width.</p>
---	--

1. Lower the tree shear to the base of the tree.

2. Turn the tree shear until the cutting blade (2) is at 90 degree angle towards the tree (1).

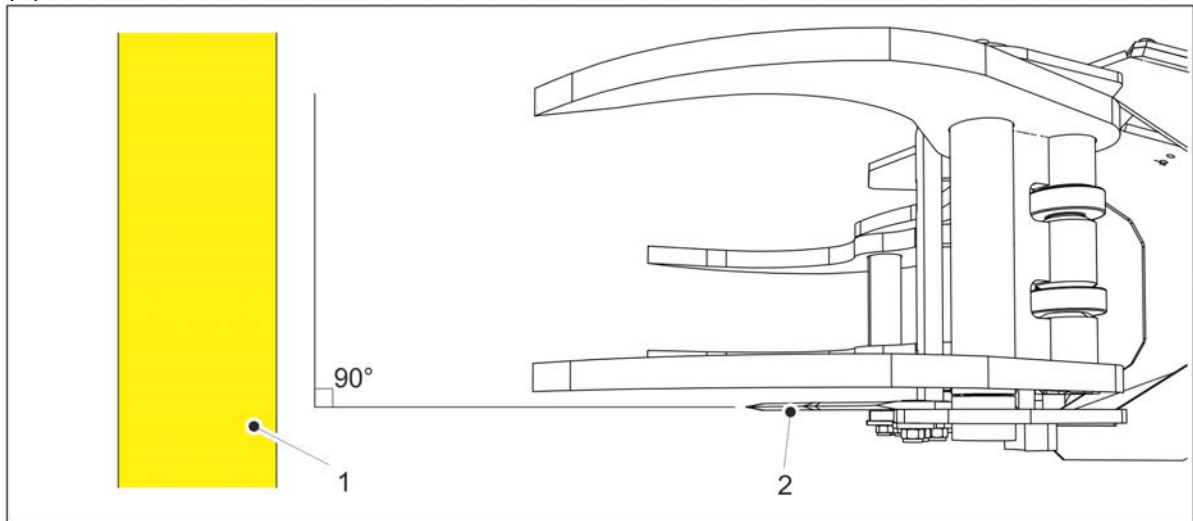

3. Place the tree (2) between the cutting side jaw (1) and the cutting blade (3).

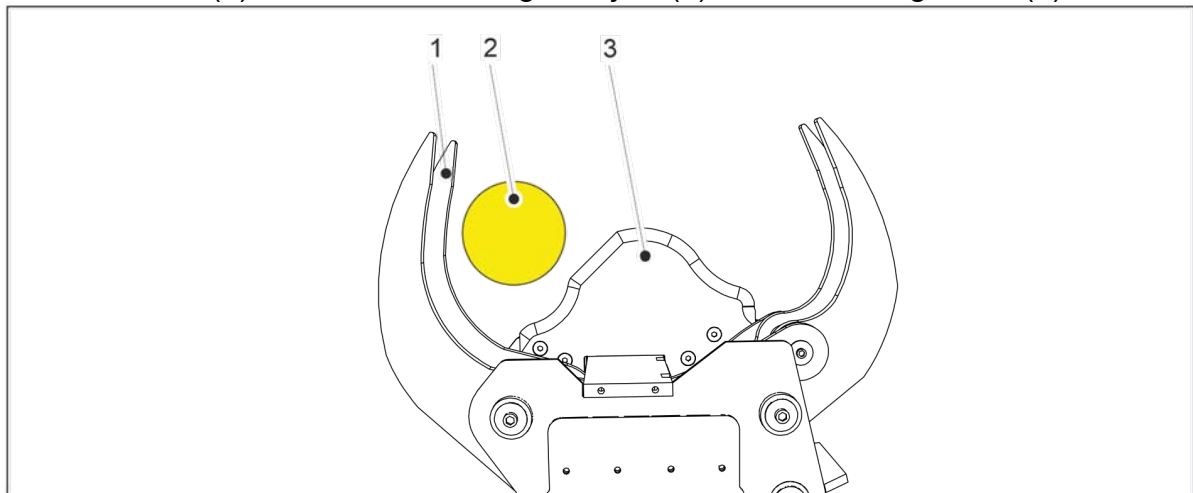

4. Close the jaws to press the tree against the blade. This will cut the tree.
5. Move the tree to a stacking location on the ground.
6. To release the tree, open the jaws.

6.2 Loading timber

When the cutting blade is detached, the tree shear can be used for loading timber. See chapter [7.3.8 Replacing the cutting blade](#) for how to detach the blade.

- Move the tree shear to the midpoint of the timber stack. Grabbing the tree from the middle will help to balance the machine.
- Close the jaws so that the timber is firmly in the tree shear.

6.3 Operation in case of malfunction

Malfunction	Action
Tree shear cannot cut a tree and becomes stuck	<p>Do not open the jaw of the tree shear. Do not approach a tree that is partially cut.</p> <p>Try to fell the tree away from the machine by pushing it with the machine.</p> <p>Check that the tree shear is not damaged before you use the tree shear again.</p>
Branches or debris in the tree shear	<p>Before removing branches or debris:</p> <ul style="list-style-type: none"> • Lower the tree shear to the ground. • Turn off the base machine.
Cutting blade detaches from the tree shear	<p>Lower the tree shear to the ground. Turn off the base machine.</p> <p>Ensure that the blade and its bolts are not damaged before reattaching the blade.</p>
Hydraulic fault, jaws do not open or close	<p>Relieve the hydraulic pressure. Check for leaks in the connectors and lines.</p> <p>Replace any faulty connectors or lines.</p>

7 MAINTENANCE

7.1 Maintenance schedule, tree shear

Task	Interval
Check the tightness of screws and nuts.	Daily
Check that there are no cracks or fractures.	Daily
Check the condition of the blade.	Daily
Check that there are no hydraulic leaks.	Daily
Grease the tree shear.	Daily
Clean the tree shear.	When needed
Sharpen the blade.	When needed
Replace the blade.	When needed

7.2 Tightening torques

Class 8.8 bolt	Tightening torque
M10	43 Nm
M12	75 Nm
M16	181 Nm
M20	353 Nm

7.3 Maintenance instructions, tree shear



NOTE

Before performing any maintenance, lower the tree shear to the ground and turn off the base machine.

7.3.1 Checking the tightness of screws and nuts

1. Check the tightness of the quick coupler bolts and nuts (1-10). The quantity of the bolts and nuts varies according to the tree shear size.

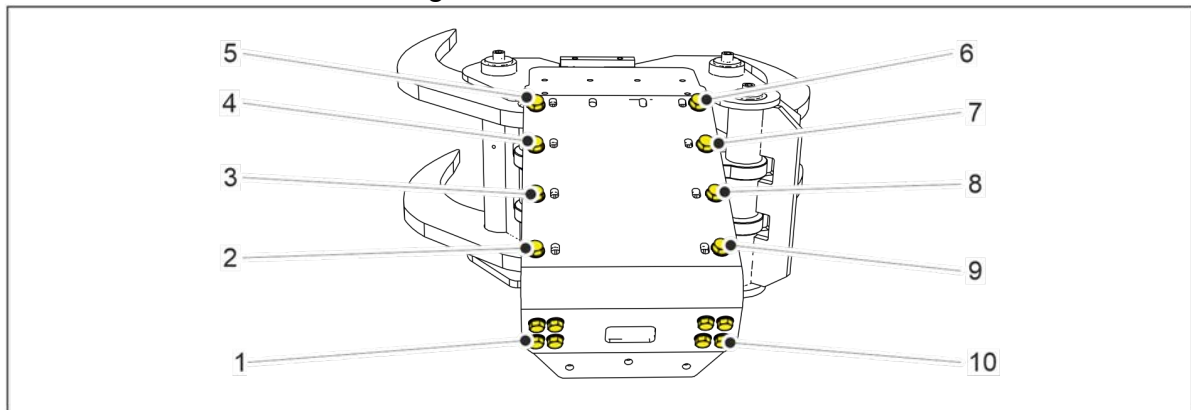

2. Check the tightness of the top bolts (1-4).

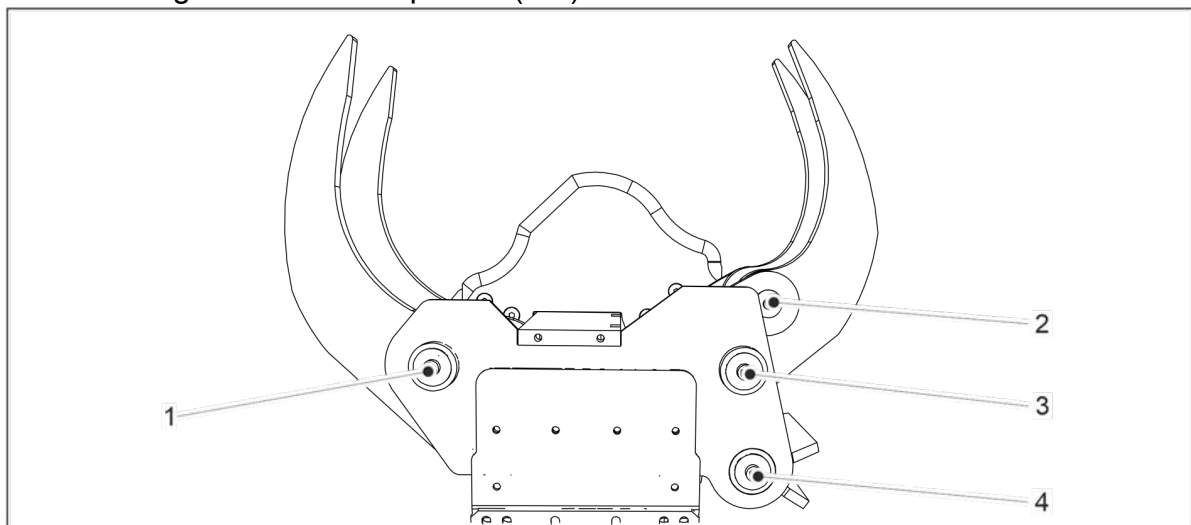

3. Check the tightness of the bottom bolts (1-3).

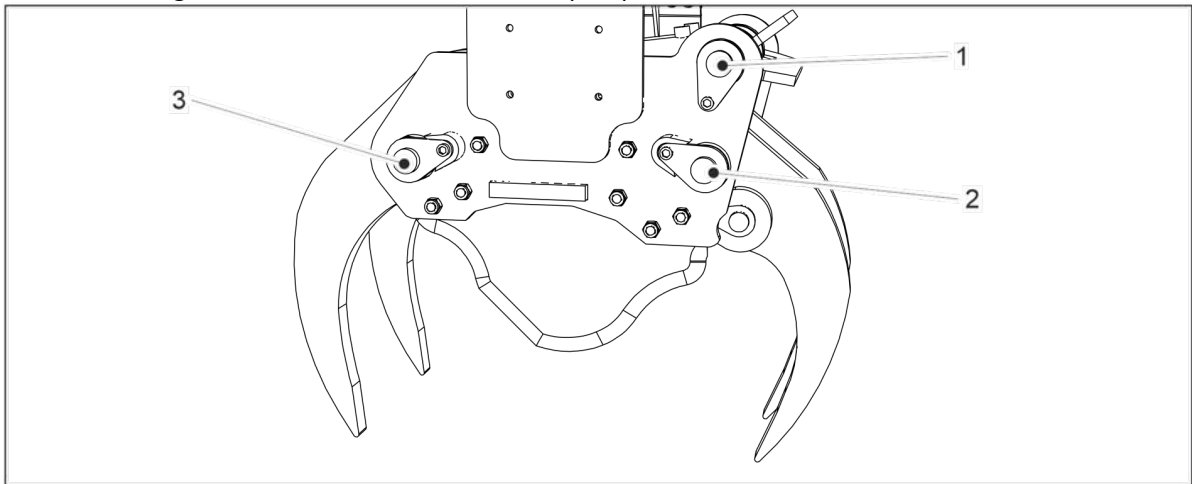

4. Check the tightness of the cutting blade bolts (7).

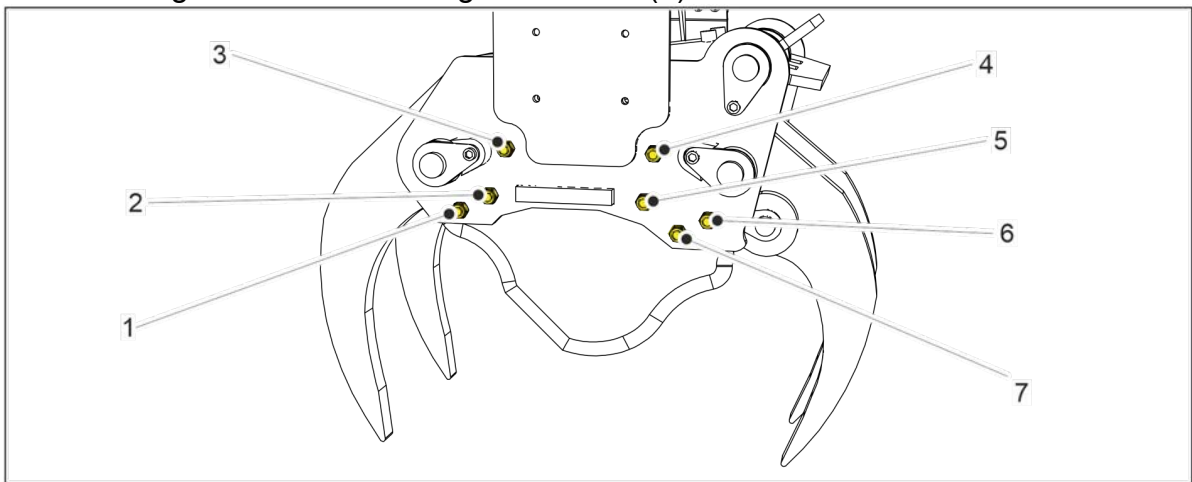

7.3.2 Checking the tree shear for cracks or fractures

Visually check the jaws and main body of the tree shear for cracks or fractures in the metal. If cracks or fractures are found, do not attempt to fix them. Instead, contact your local dealer.



7.3.3 Checking the condition of the cutting blade

	<p>DANGER</p>
	<p>Sharp blade hazard</p>
	<p>The blade can cause injuries and cuts.</p>
	<p>Observe caution when near the blade. Wear protective gloves when you handle the blade.</p>

Visually check that the blade is not damaged, bent or dull. If the blade is dull or notched, sharpen it. Damaged or bent blade must be replaced.

7.3.4 Checking for hydraulic leaks

	<p>DANGER</p> <p>Crushing hazard</p> <p>Moving parts in the tree shear can cause injuries or even death.</p> <p>Observe caution near the tree shear when the hydraulic lines are connected. Do not put your hands inside the tree shear when the hydraulic lines are connected.</p>
---	---

  	<p>DANGER</p> <p>Hydraulic fluid</p> <p>High pressure hydraulic fluid can cause injury or even death.</p> <p>Relieve the hydraulic pressure before maintenance. Wear protective gloves and goggles when handling hydraulic fluid.</p>
--	---

Visually check the inflow and outflow hydraulic connections for leaks. Hydraulic leaks are more common in cold operating temperatures. If possible, pre-heat the hydraulic oil of the base machine before operation in cold temperatures.

If a leak is found, replace the hydraulic hose or connector.

7.3.5 Greasing the tree shear

Use good quality NLGI.2 multi-purpose grease for greasing the tree shear.



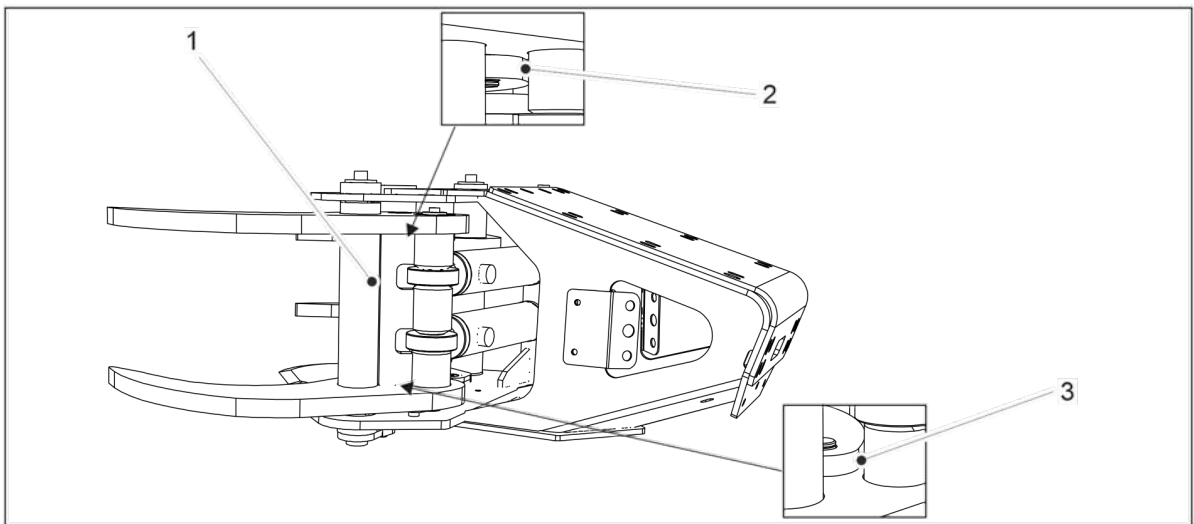
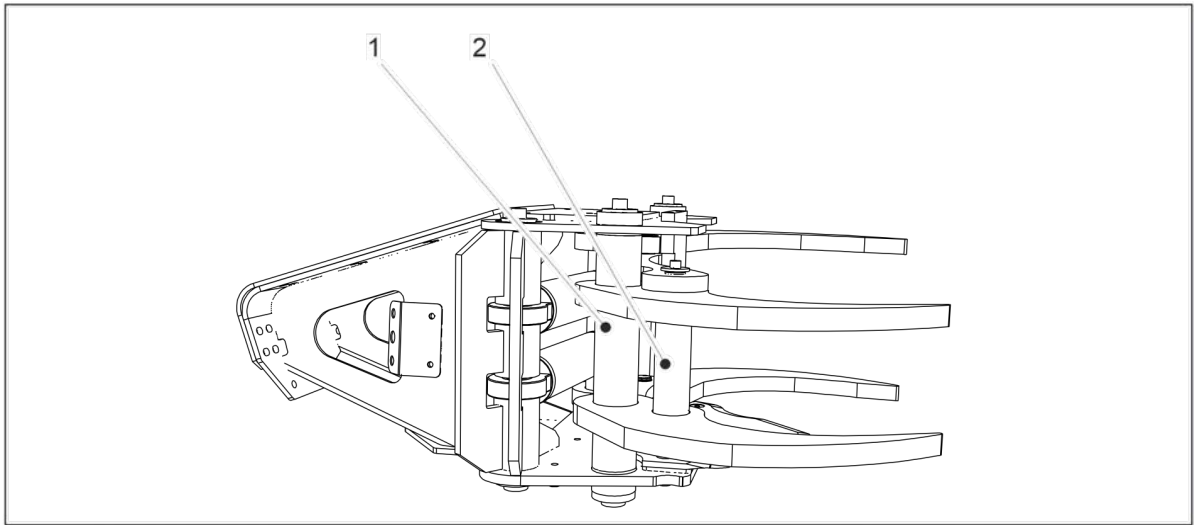

1. Add grease to the grease nipples. The location of the grease nipples is shown below.



7.3.6 Cleaning the tree shear

The tree shear can be washed using a pressure washer. Check that no branches or debris remain inside the tree shear after washing.

7.3.7 Sharpening the cutting blade



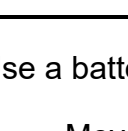

	<p>DANGER</p>
	<p>Sharp blade hazard</p>
	<p>The blade can cause injuries and cuts.</p>
	<p>Observe caution when near the blade. Wear protective goggles and gloves when you sharpen the blade.</p>

	<p>NOTE</p>
	<p>Excessive heat during sharpening can weaken the structure of the blade.</p>

Use a battery powered angle grinder equipped with an abrasive disc for sharpening.

- Move the abrasive disc continuously when sharpening.
- Pause the sharpening if the blade becomes hot and let it cool down.
- Sharpen the blade equally from both sides.

7.3.8 Replacing the cutting blade

	<p>DANGER</p>
	<p>Sharp blade hazard</p>
	<p>The blade can cause injuries and cuts.</p>
	<p>Observe caution when near the blade. Wear protective gloves when you handle the blade.</p>

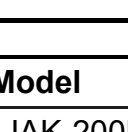
	<p>NOTE</p>
	<p>Use an electrical wrench or alternatively a socket wrench with a 1 m extender at least.</p>

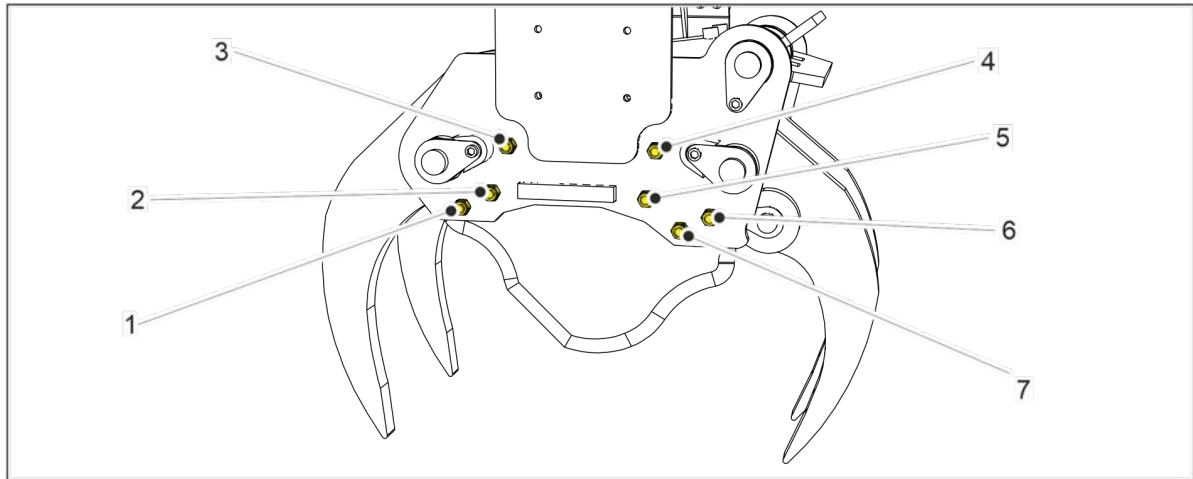

Model	Part	Part number
JAK-200B	Blade GEN2	11203
JAK-250B	Blade GEN2	11204
JAK-300B	Blade GEN2	11205

1. Remove the cutting blade nuts (1-7) at the bottom of the tree shear.



2. Remove the cutting blade bolts.
3. Remove the old blade.
4. Align the new blade with the bolt holes.
5. Attach the bolts.
6. Attach the nuts.

7.3.9 Replacing the hydraulic hose and connector

	DANGER
	Hydraulic fluid
	
	High pressure hydraulic fluid can cause injury or even death. Relieve the hydraulic pressure before maintenance. Wear protective gloves and goggles when handling hydraulic fluid.

1. Determine whether a hose or connector is the cause of the leak.
2. Prepare a spare hose or connector according to the leak.
3. Depressurize the hydraulic lines in the base machine. See manufacturers documentation.
4. Turn off the base machine.
5. Put a container underneath the hydraulic connection for any oil that might spill out.
6. Detach the leaking connector or connectors of the hose segment.
7. Attach the new connector or hose segment with its connectors.

7.4 Spare parts and maintenance contacts

For spare parts and service, contact your local dealer. When ordering spare parts, indicate the model and serial number of the tree shear. The information is found on the manufacturer's plate.

8 OPTIONS

8.1 Optional equipment available

Optional equipment	JAK-200B	JAK-250B	JAK-300B
Collector unit GEN2	x	X	X
Felling support	X	X	X
Coupling options for excavators	X	X	X
Solid extension	X	X	X
LP cylinder		X	X
Foot	X	X	X
Guillotine unit			X
3-finger jaw	X	X	X
eBoost		X	X
Cable control (incl. 6/2 valve)	(X)	X	X
Radio control (Incl 6/2 valve)		(X)	x

(X) Only without eBoost

8.2 Collector unit

8.2.1 Overview

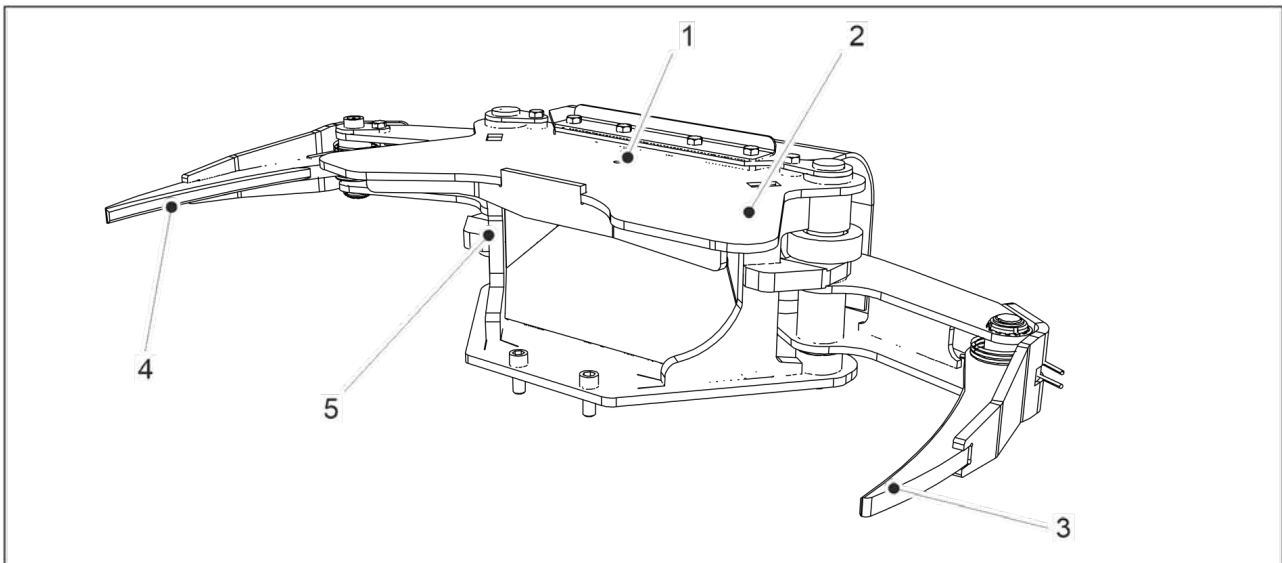

1	Lifting loop thread
2	Tree support
3	Left jaw

8 Options

4	Right jaw
5	Collector unit frame

The collector unit has two smaller hydraulic jaws that collect and hold the cut trees while the tree shear falls more trees. When the collector unit is full, the cut trees can be moved to a new location as a bunch to save time. The collector unit is especially useful when cutting densely growing smaller trees. The collector unit is installed on top of the tree shear.

8.2.1.1 Product identification

The location of the manufacturer's plate (1) is shown below.

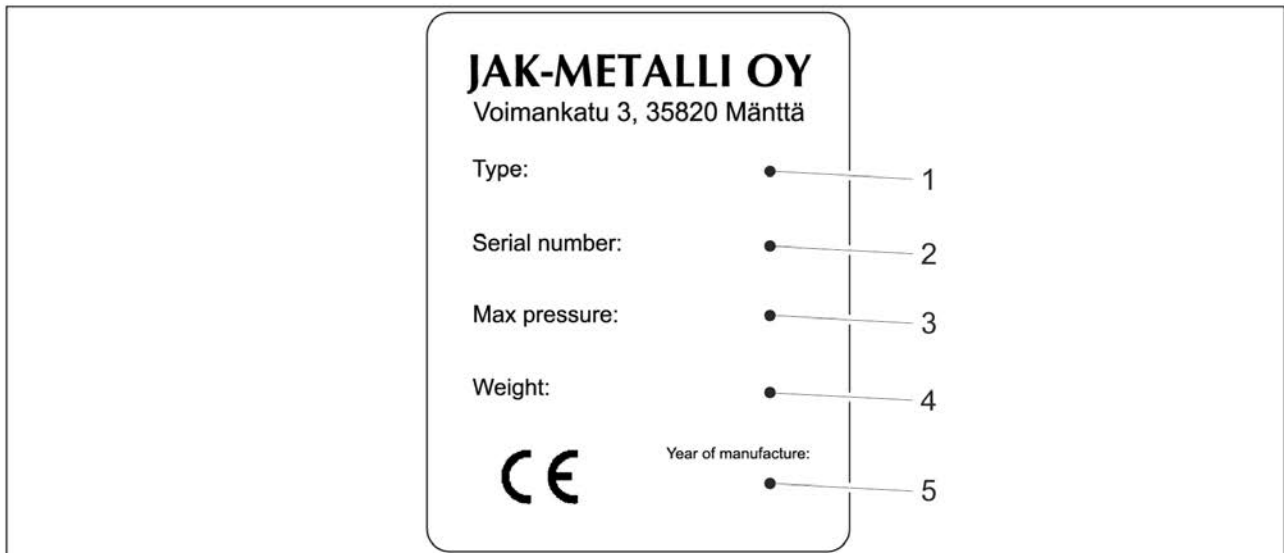
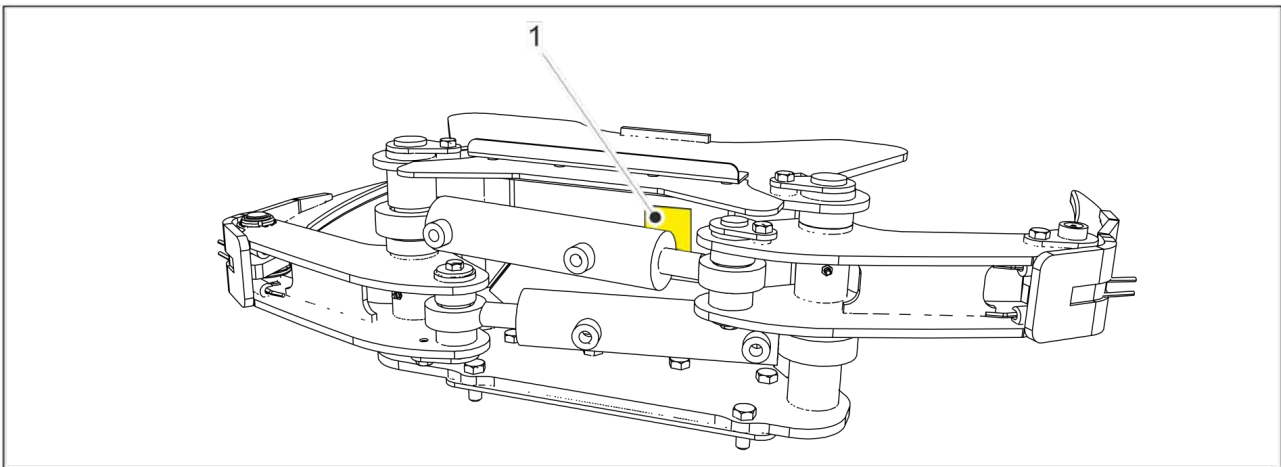

Location	Information
1	Type
2	Serial number
3	Maximum pressure
4	Weight
5	Year of manufacture

8.2.2 Installation

8.2.2.1 Lifting the collector unit

	<p>DANGER</p> <p>Lifting hazard</p> <p>The unit is heavy and can cause injuries if lifted.</p> <p>Do not lift the unit on your own. Use a lifting aid.</p>
---	--

Product name	JAK-200B	JAK-250B	JAK-300B
Collector unit weight	55 kg (121.2 lbs)	77 kg (169.7 lbs)	120 kg (264.5 lbs)

The unit can be lifted using a lifting strap or hook. Install the lifting loop (1) on top of the collector unit for lifting.

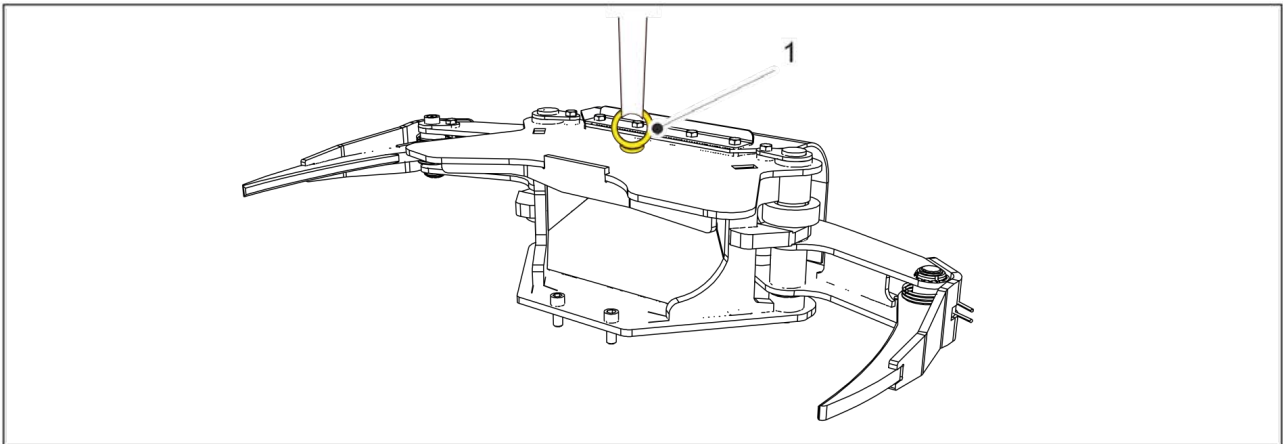

8.2.2.2 Installing the collector unit

	<p>Installing the collector unit raises the weight of the tree shear and can affect balance.</p>
---	--

1. Clean the threads using pressurized air and degreaser.

2. Move the collector unit above the tree shear.

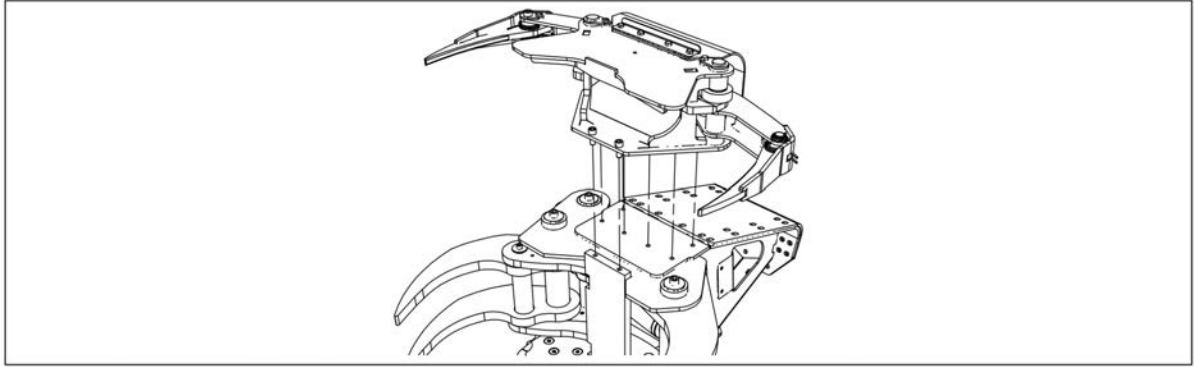

3. Tighten the bolts.
4. Install the hydraulic lines to the connectors at the back of the collector unit: right connector closes, left connector opens.

8.2.3 Operation

8.2.3.1 Operating the collector unit



WARNING

Risk of damage to the equipment

Before you cut a tree, make sure the collector unit is closed.



NOTE

Cut the tree bundle on the ground if the bundle is too long to be transported from the stacking location.

1. Make sure the collector unit (1) is closed.

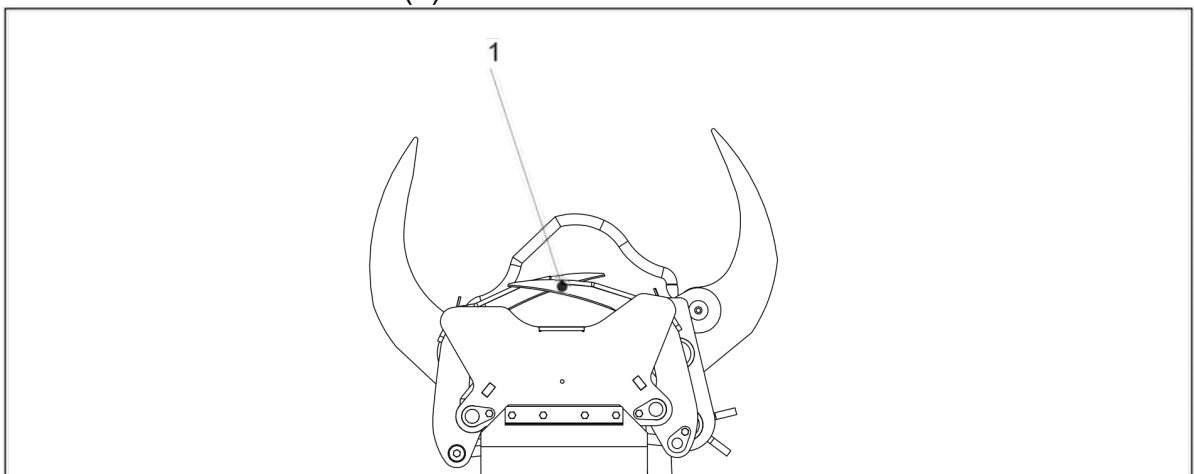

2. Place the tree bundle between the cutting side jaws (1) and the cutting blade (2). The collector unit (3) must be closed.

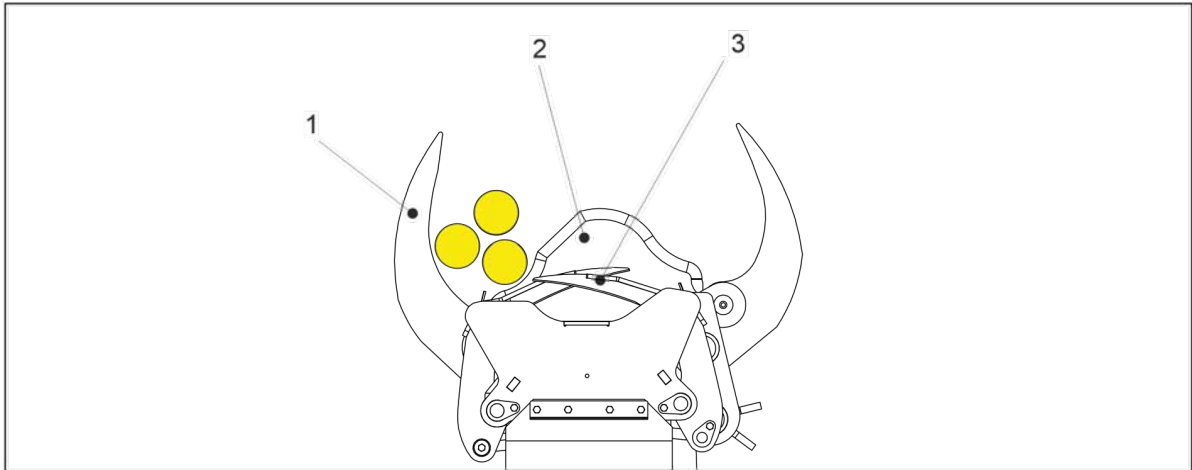

3. To cut the tree bundle, close the jaws (1). Now the jaws hold the tree bundle. The collector unit (2) is closed.

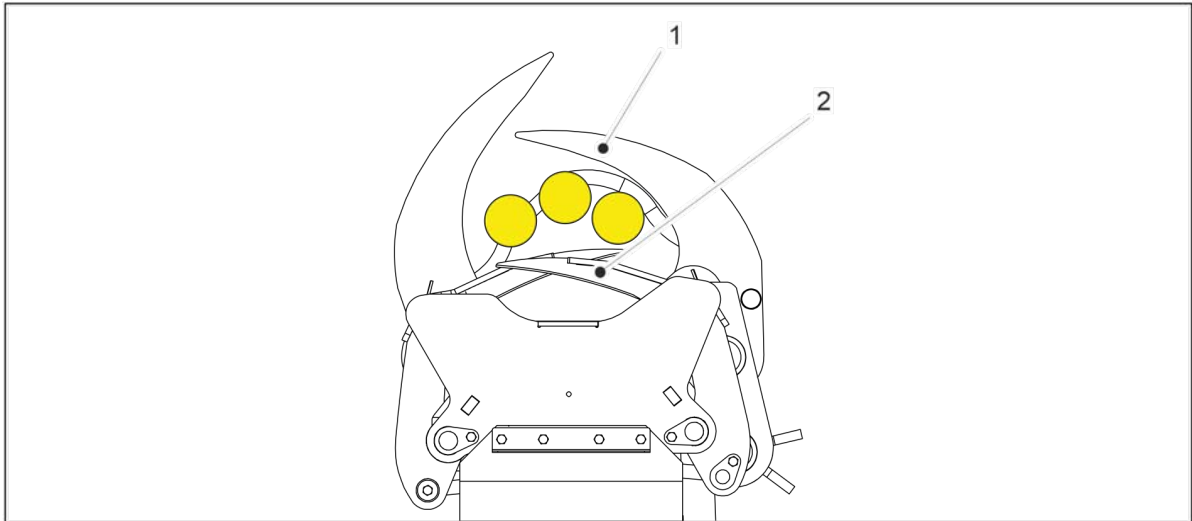

4. Open the collector unit (1).

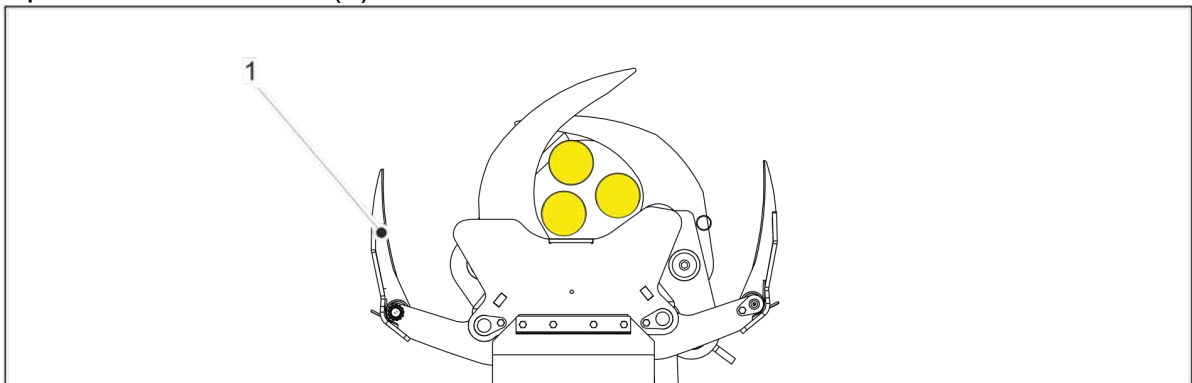

5. Close the collector unit (1).

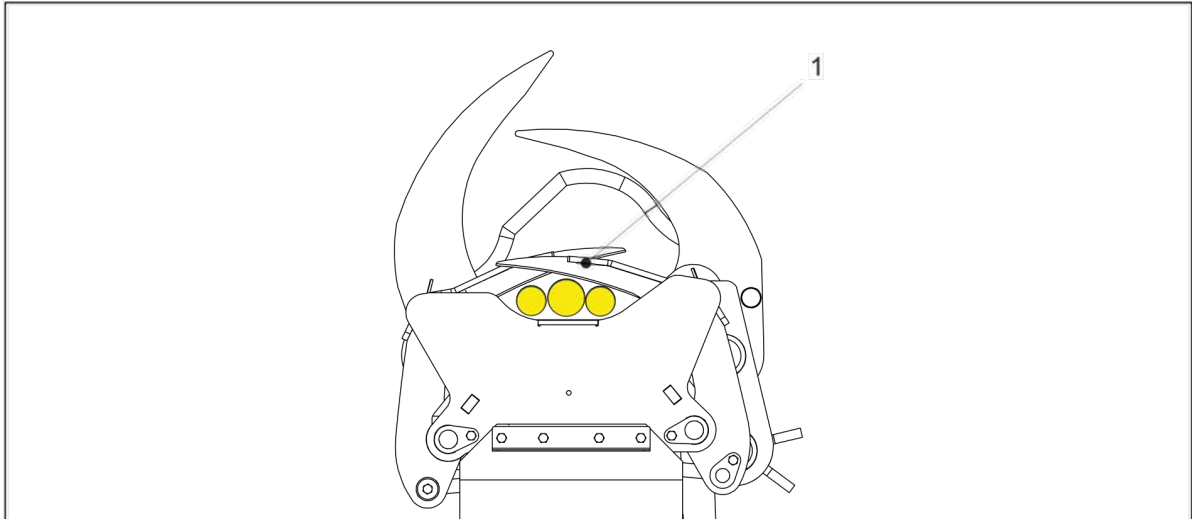

6. Open the jaws (1). Now the collector unit (2) holds the tree bundle.

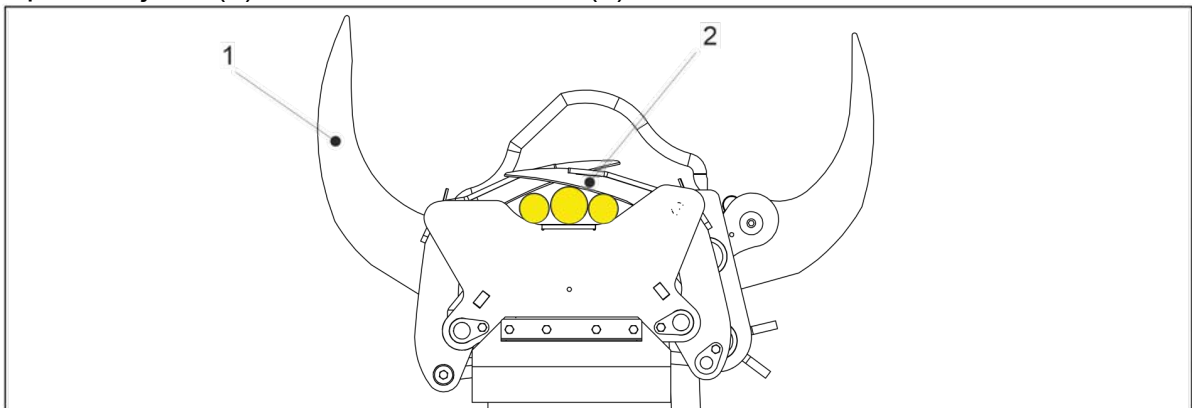

7. Repeat steps 1, 2, 3, 4, 5 and 6 until the jaws can no longer cut the tree or the collected tree bundle becomes unstable.



NOTE

Long tree trunks are more unstable than short trunks. Danger of falling trunks and branches. Observe the collected tree bundle in case it starts to fall apart.

8. After the last succeeded cut, close the jaws.
9. Move the tree bundle to a stacking location on the ground.

10. To release the tree bundle, open the collector unit first and after that open the jaws.

	<p>WARNING Risk of damage to the equipment Always open the collector unit first when releasing the tree bundle on the ground. This way the collector unit doesn't hold all the weight of the tree bundle.</p>
---	---

8.2.4 Daily maintenance

Maintenance tasks
Grease the collector unit
Clean the collector unit
Check the collector unit

8.2.4.1 Greasing

Use good quality NLGI.2 multi-purpose grease for greasing.

Apply grese to the grese nipples (1-6).

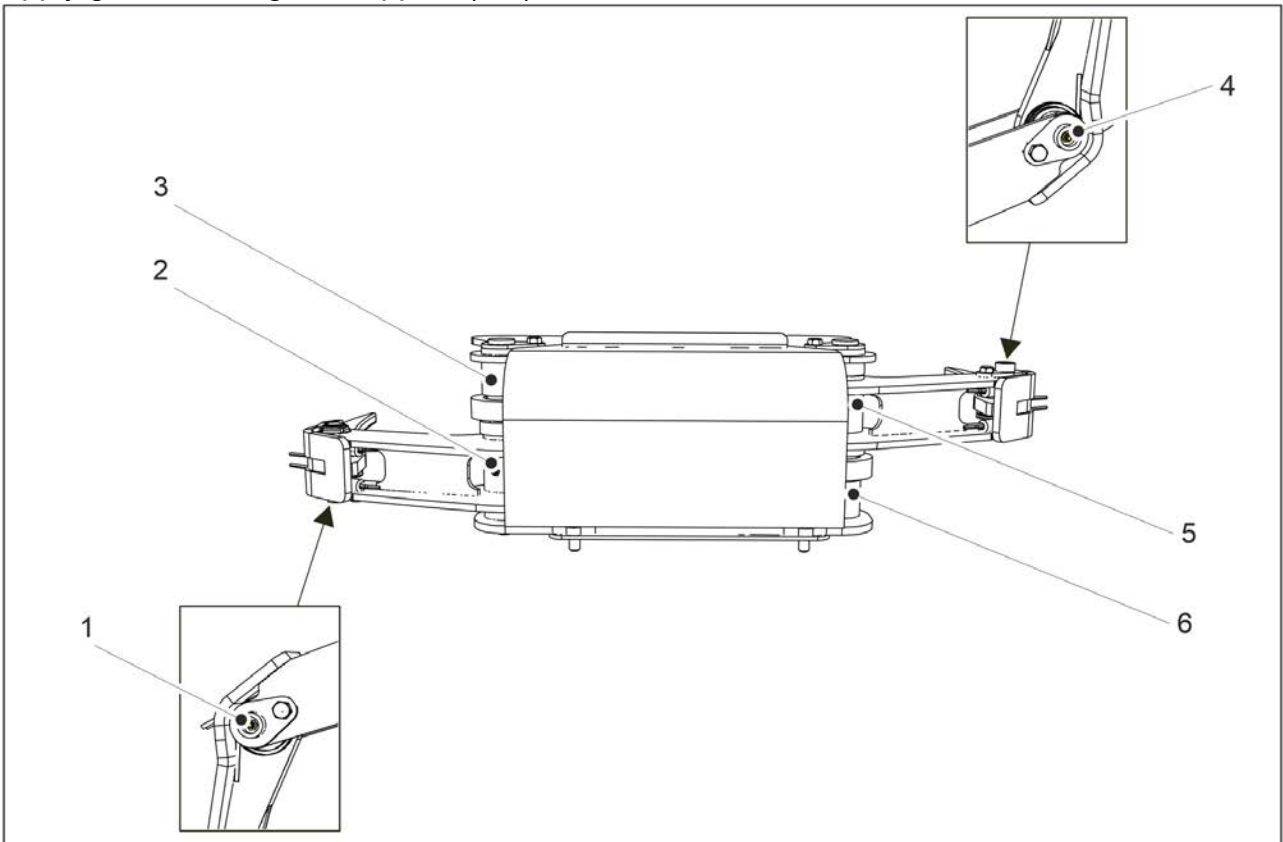

8.2.4.2 Cleaning the collector unit

After using the collector unit, clear out any branches, snow or debris from inside the unit. The unit can be washed with a pressure washer.

8.2.4.3 Checking the collector unit

1. Check the tightness of the bolts.
2. Check that there are no hydraulic leaks.
3. Check that there are no cracks or fractures in the collector unit.

8.3 Guillotine unit

8.3.1 Overview

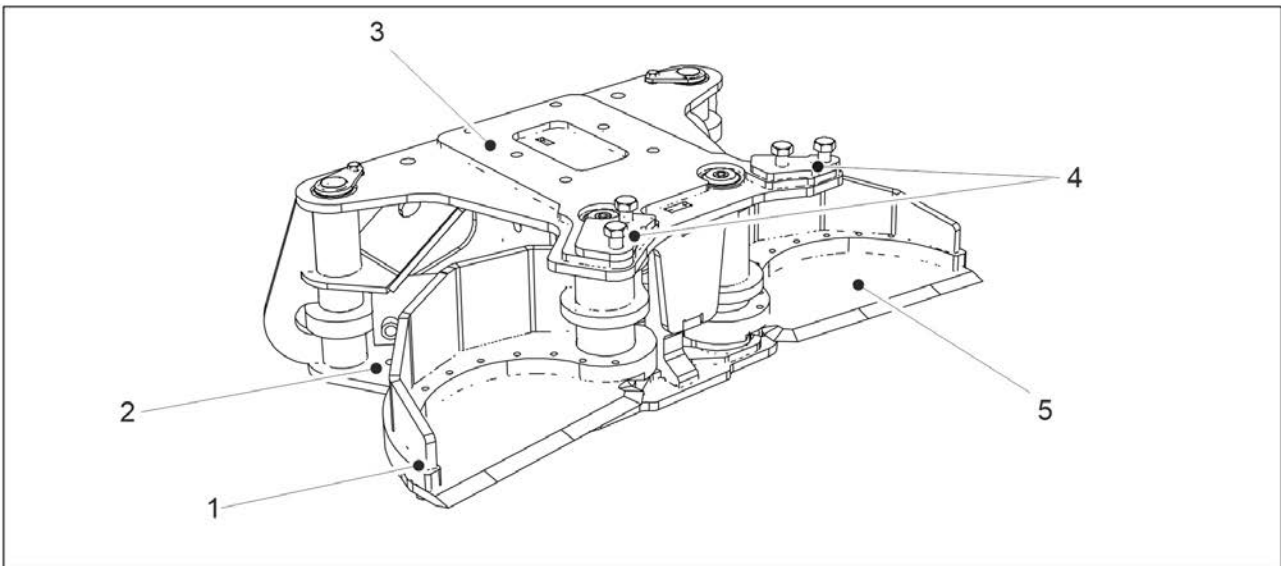

1	Right guillotine jaw
2	Guillotine unit frame
3	Top mounting surface
4	Front mounting surfaces
5	Left guillotine jaw

The guillotine unit has two hydraulically controlled cutting blades, which can cut thicker and tougher trees than the tree shear blade. The unit can cut wood up to a width of 350 mm. The guillotine unit also effectively cuts small trees and bushes that tend to bend.

Operation

When the guillotine unit is installed, the jaws of the tree shear close first to hold the tree. The cutting blades of the guillotine unit will then close and cut the tree. The tree will remain in hold of the tree shear jaws after cutting. This allows the tree shear to be used simultaneously for cutting, loading and handling wood with the guillotine unit attached.

8.3.2 Product identification

The guillotine unit has a manufacturer's plate (1) on the right side of the frame.

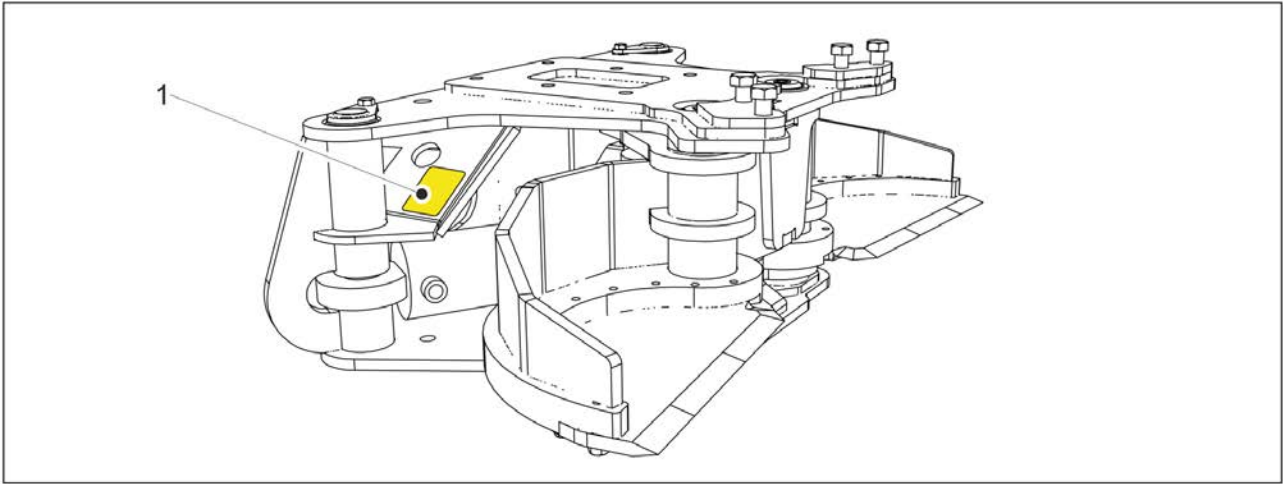

JAK-METALLI OY
Voimankatu 3, 35820 Mänttä

Type: ● ————— 1

Serial number: ● ————— 2

Max pressure: ● ————— 3

Weight: ● ————— 4

Year of manufacture: ● ————— 5

CE

Location	Information
1	Type
2	Serial number
3	Maximum pressure
4	Weight
5	Year of manufacture

8.3.3 Installation

8.3.3.1 Lifting the guillotine unit



DANGER

Lifting hazard

The unit is heavy and can cause injuries if lifted.

Do not lift the unit on your own. Use a lifting aid.

Guillotine unit weight: 290 kg (639 lbs)

Use a lifting strap (1) through the frame for lifting the guillotine unit.

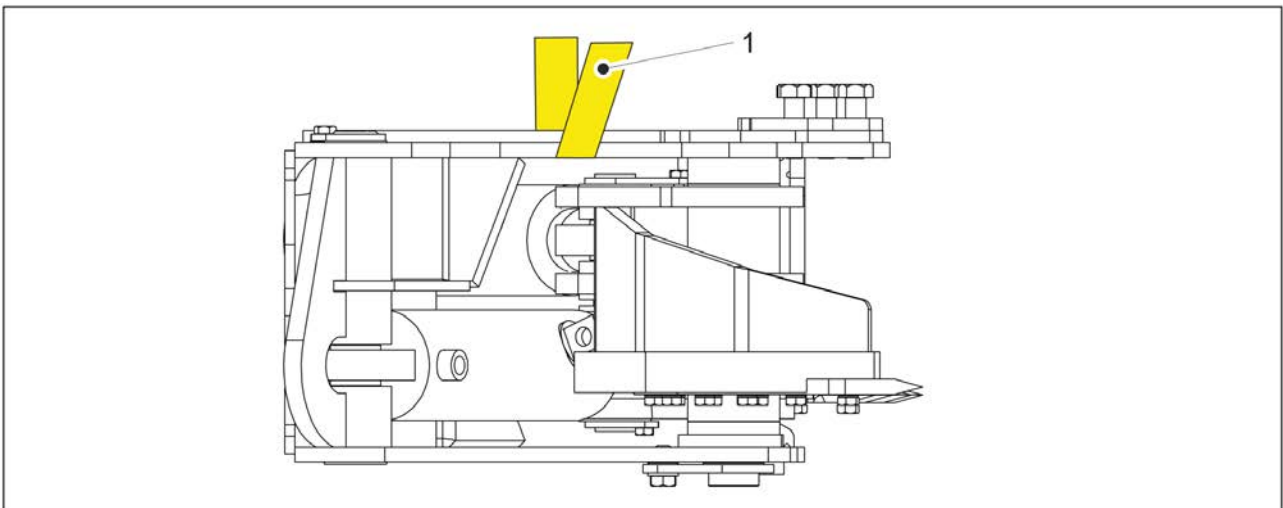

8.3.3.2 Installing the guillotine unit

1. Detach the cutting blade from the tree shear if it is attached.
2. Lift the guillotine unit to a stable surface.
3. Lower the bottom of the tree shear to the top of the guillotine unit.
4. Align the bolt holes on the tree shear and guillotine unit.

5. Attach the bolts and nuts (1-4) at the front of the guillotine unit.

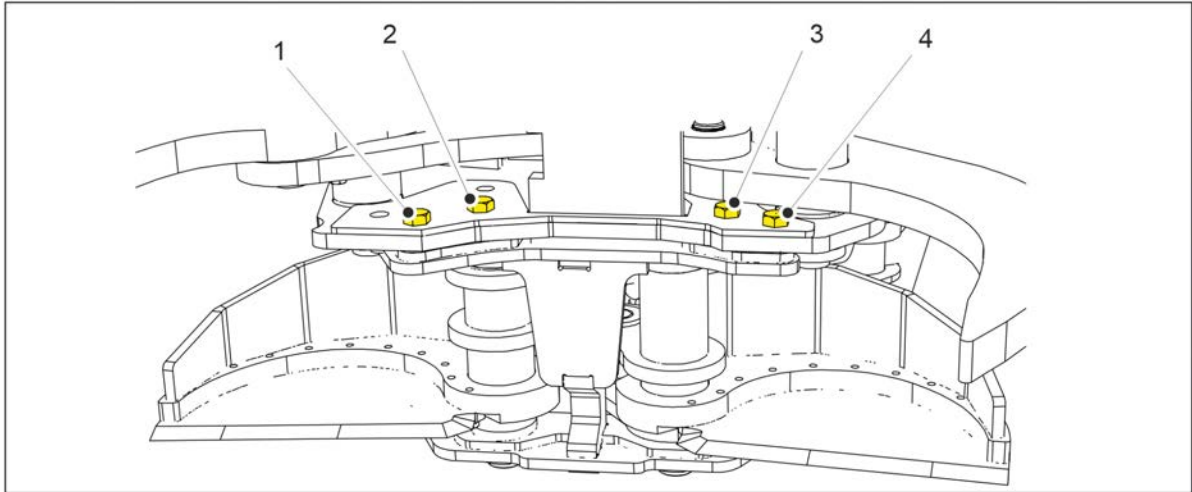

6. Attach the middle connection bolts (1), 6 pcs.

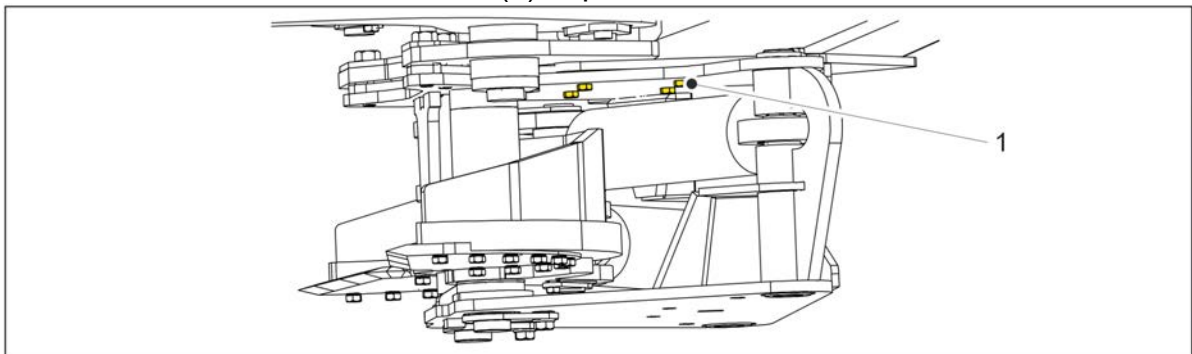

7. Attach the inflow and outflow hydraulic hoses for the guillotine unit.

8.3.4 Maintenance

8.3.4.1 Daily maintenance

8.3.4.1.1 Greasing the guillotine unit

Use good quality NLGI.2 multi-purpose grease for greasing the guillotine unit.

1. Apply grease to the grease nipples on the right side of guillotine unit (1-3).

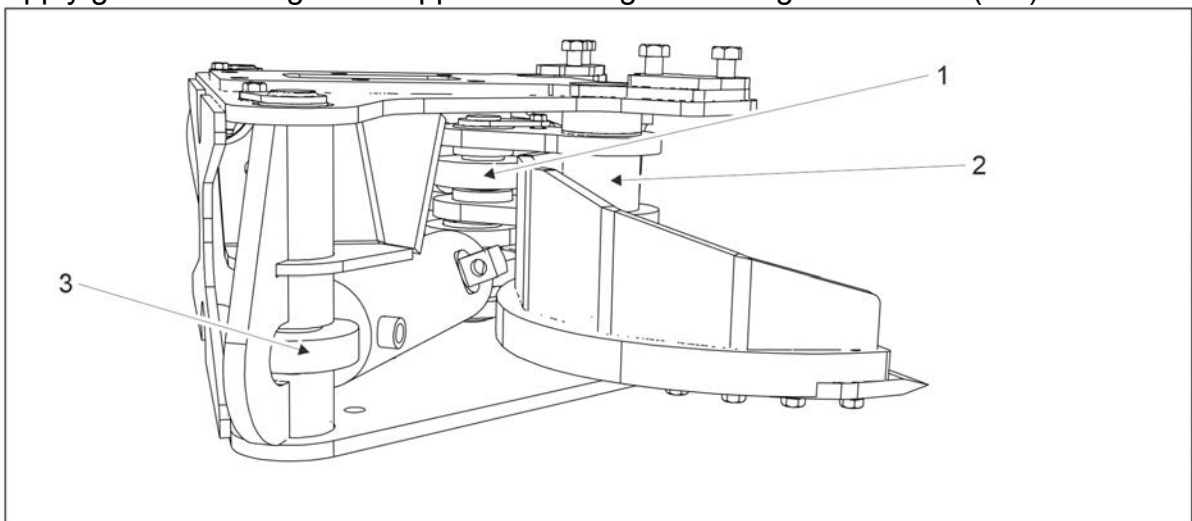

2. Apply grease to the grease nipples on the left side of guillotine unit (1-3).

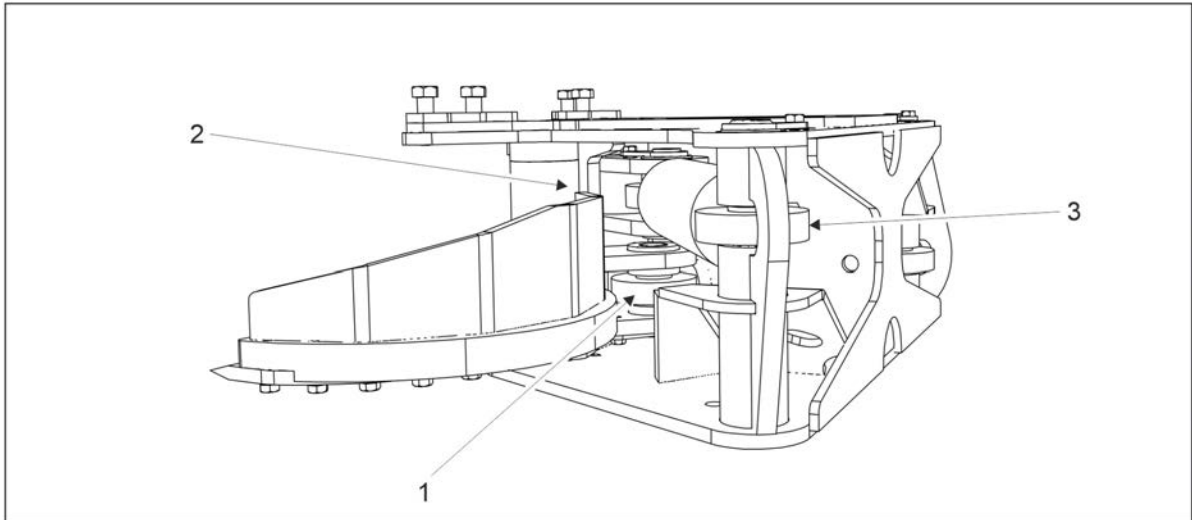

8.3.4.1.2 Checking the guillotine unit

1. Check the tightness of the upper front bolts (1-4).

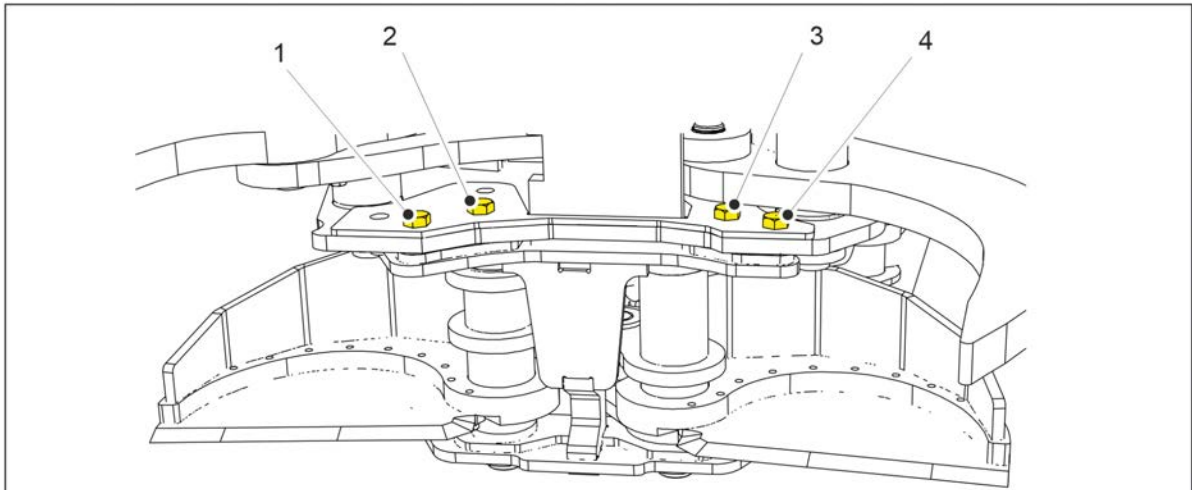

2. Check the tightness of the bottom front bolts (1-2).

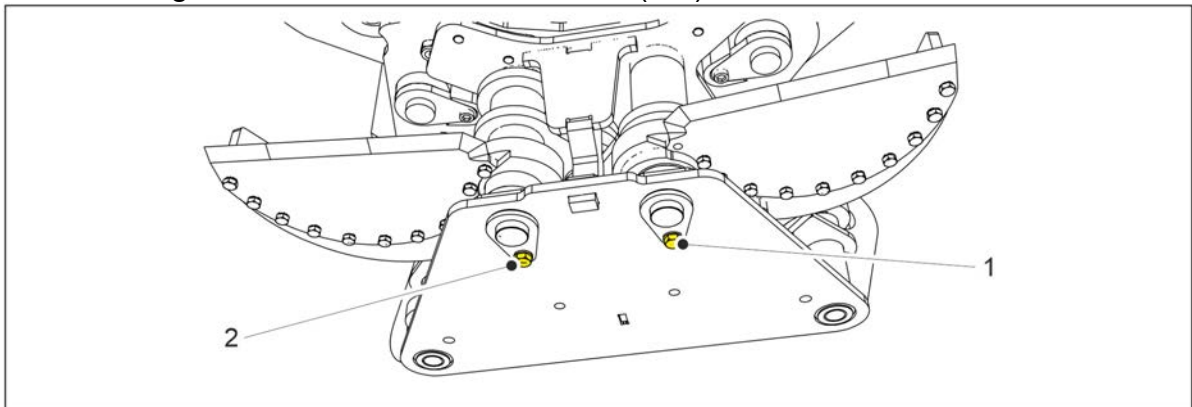

3. Check the tightness of the back upper bolts (1-2).

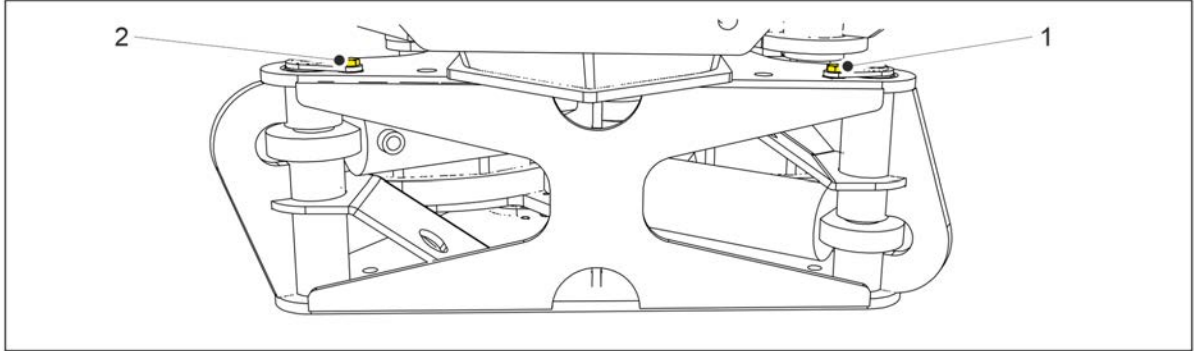

4. Check the tightness of the middle connection bolts (1), 6 pcs.

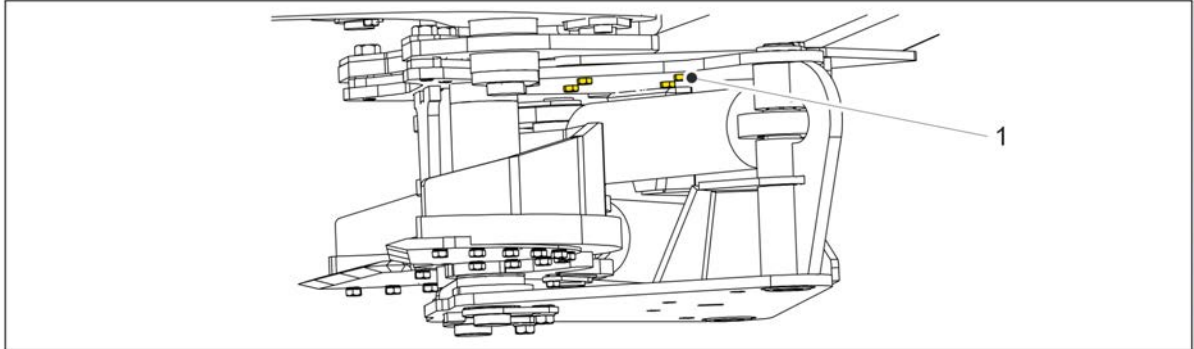



5. Check that there are no hydraulic leaks.
6. Check that there are no cracks or fractures on the guillotine unit.

8.3.4.1.3 Cleaning the guillotine unit

After using the guillotine unit, clear out any branches, snow or debris from inside the unit. The unit can be washed with a pressure washer.

8.3.4.2 Replacing the guillotine blades

	DANGER Sharp blade hazard
	The blade can cause injuries and cuts. Observe caution when near the blade. Wear protective gloves when you handle the blade.

1. Lower the tree shear to a stable surface with the front tilted upwards and the guillotine jaws open.

2. Detach the guillotine blade bolts (1).

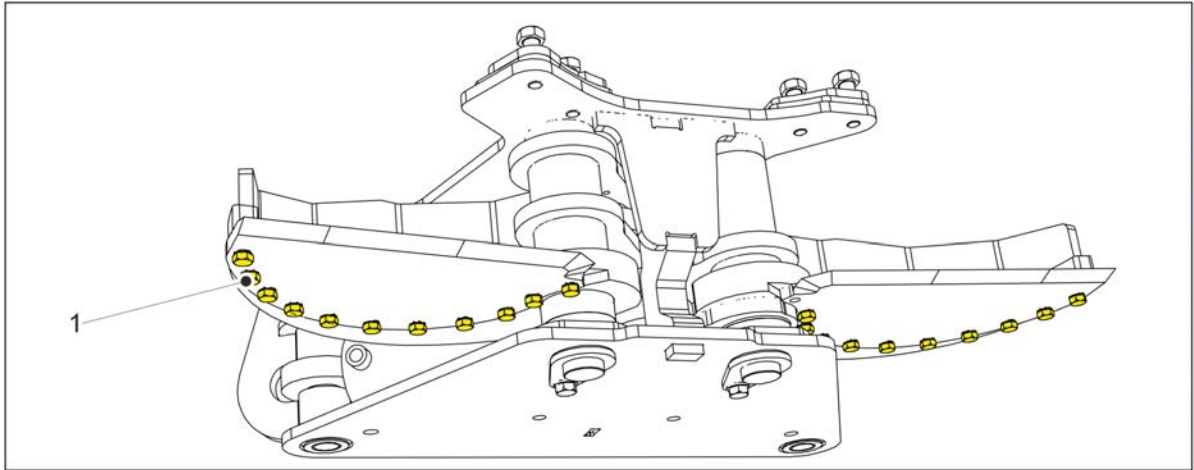

3. Remove the old blades.
4. Insert the new blades.
5. Attach guillotine blade bolts.

8.4 Felling support

8.4.1 Overview

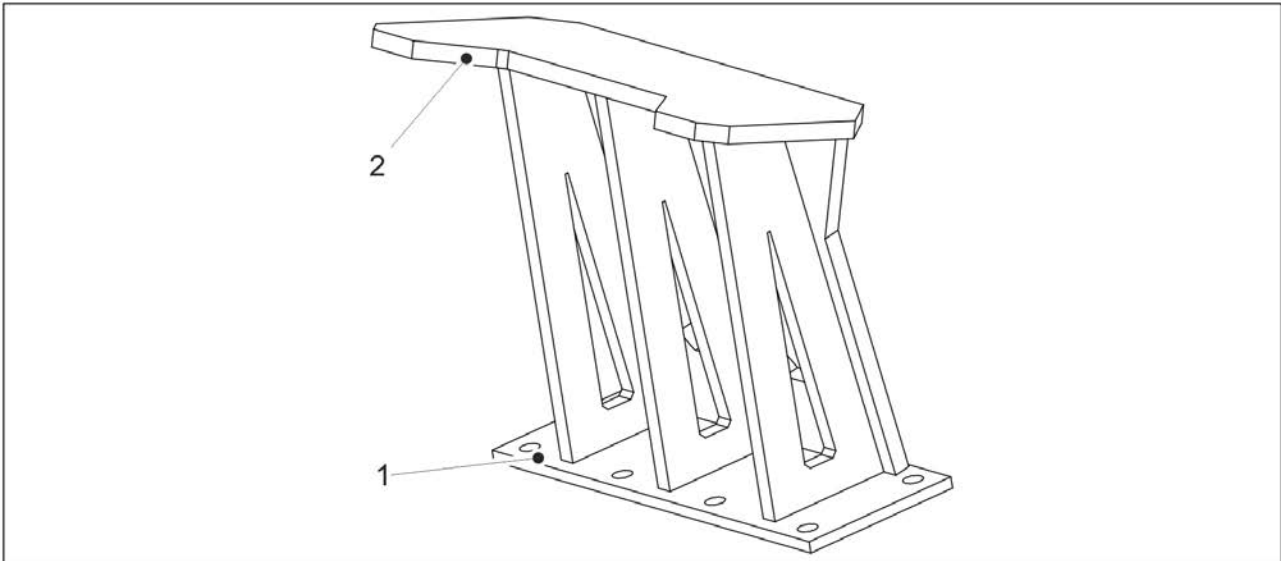

1	Connecting plate
2	Tree support

The felling support adds more height to the buffer plate of the tree shear. The height makes it easier to control the felled tree and keep it intact after cutting. The felling support is necessary for example when felling trees that are fragile due to decay.

Product name	JAK-200B	JAK-250B	JAK-300B
Felling support weight	9 kg (19.8 lbs)	13 kg (28.6 lbs)	33 kg (72.7 lbs)

8.4.2 Installation

1. Clean the attachment surface on top of the tree shear.

2. Lower the felling support (1) on top of the attachment surface (2) on the tree shear.

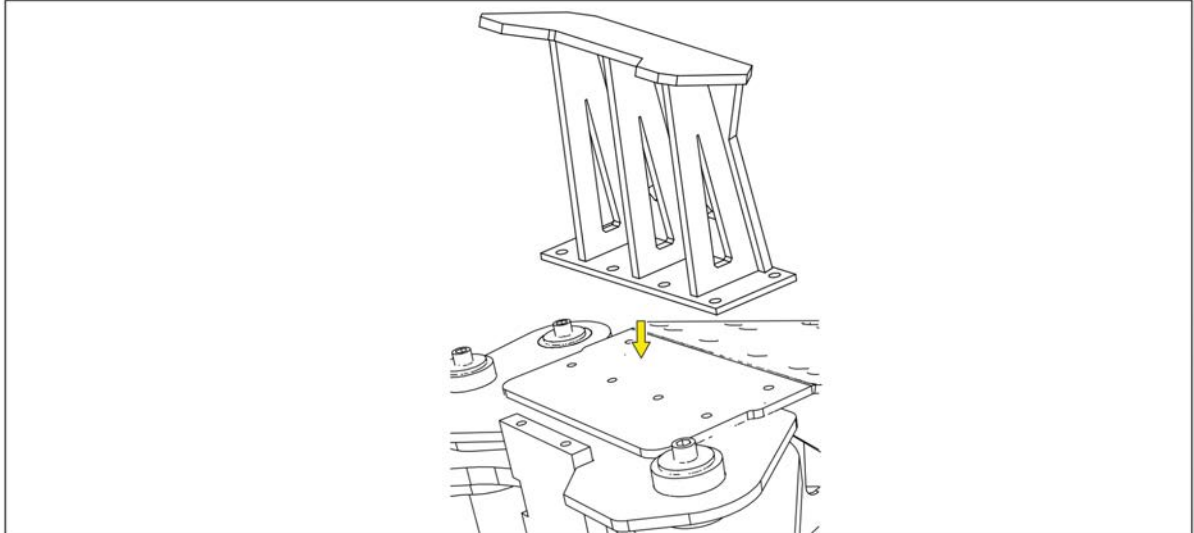

3. Align the felling support with the bolt holes on the tree shear.
4. Attach the bolts. The quantity of bolts varies according to the tree shear size.

8.4.3 Daily maintenance

1. Check the tightness of the attachment bolts.
2. Check that there are no cracks or fractures on the felling support.

8.5 Foot

8.5.1 Overview

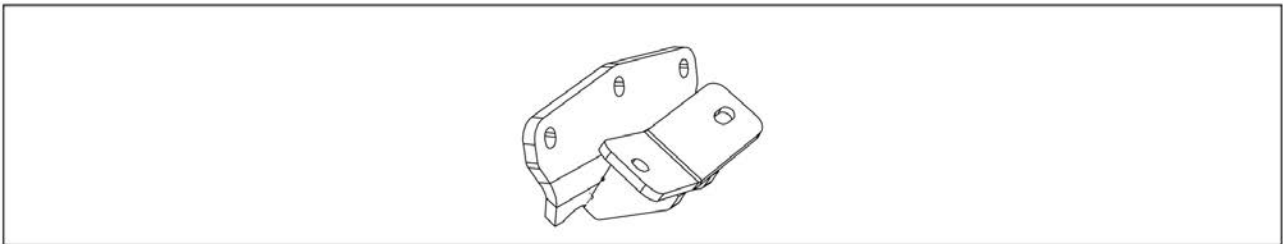

The foot is available for use with the excavator adapter. The foot is used as a support point for moving the excavator at the work site. The foot is attached to the back bottom side of the excavator adapter.

Product name	JAK-200B	JAK-250B	JAK-300B
Foot weight	3 kg (6.6 lbs)	3 kg (6.6 lbs)	7 kg (15.4 lbs)

8.5.2 Installation

1. Align the foot to the excavator adapter with the bolts.

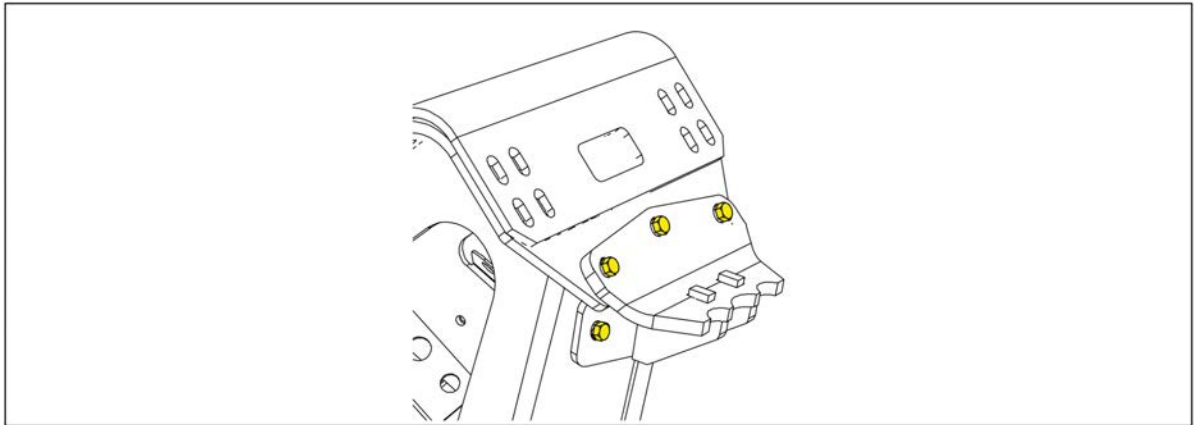

2. Attach the nuts to the bolts.

8.6 Solid extension

8.6.1 Overview

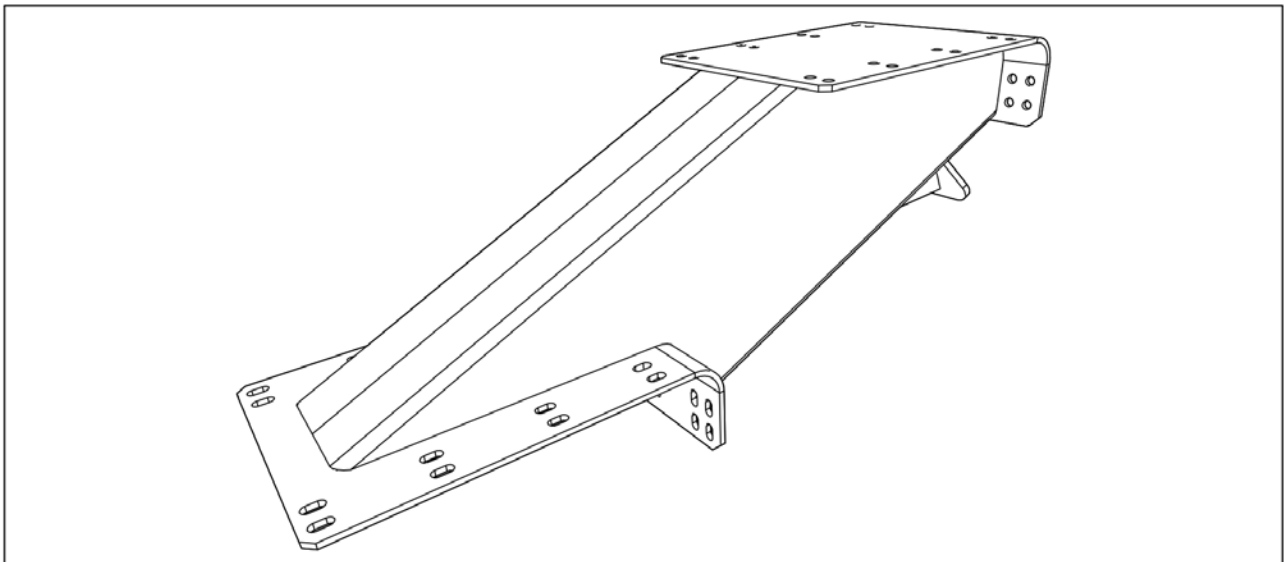

Solid extension brings additional reach to the work.

8.6.2 Installation

8.6.2.1 Lifting the solid extension

	DANGER
	Lifting hazard
	The solid extension is heavy and can cause injuries if lifted. Do not lift the solid extension on your own. Use a lifting aid.

Product name	JAK-200B	JAK-250B	JAK-300B
Solid extension weight	48 kg (106 lbs)	100 kg (220 lbs)	175 kg (386 lbs)

1. Make a loop around the solid extension with a lifting belt (1).

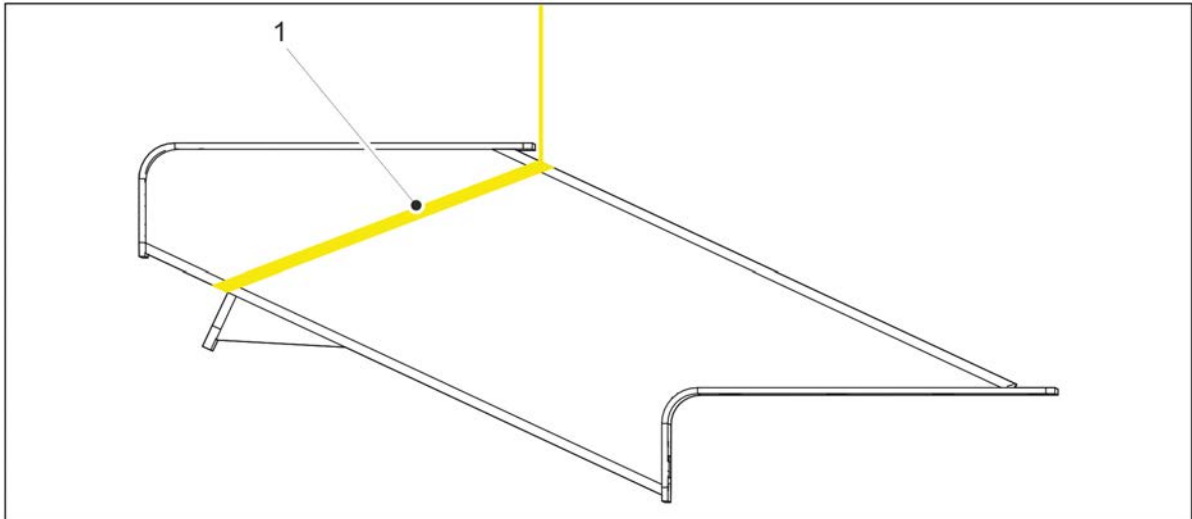

2. Lift the solid extension.

	NOTE
	The solid extension has sharp edges. Use a coated lifting belt.

8.6.2.2 Installing the solid extension

	NOTE
	Installing the solid extension raises the weight of the tree shear and can affect balance.

1. Clean the surfaces.
2. Lift the solid extension.
3. Move the solid extension above the tree shear.

4. Tighten the connecting bolts in areas (1) and (2).

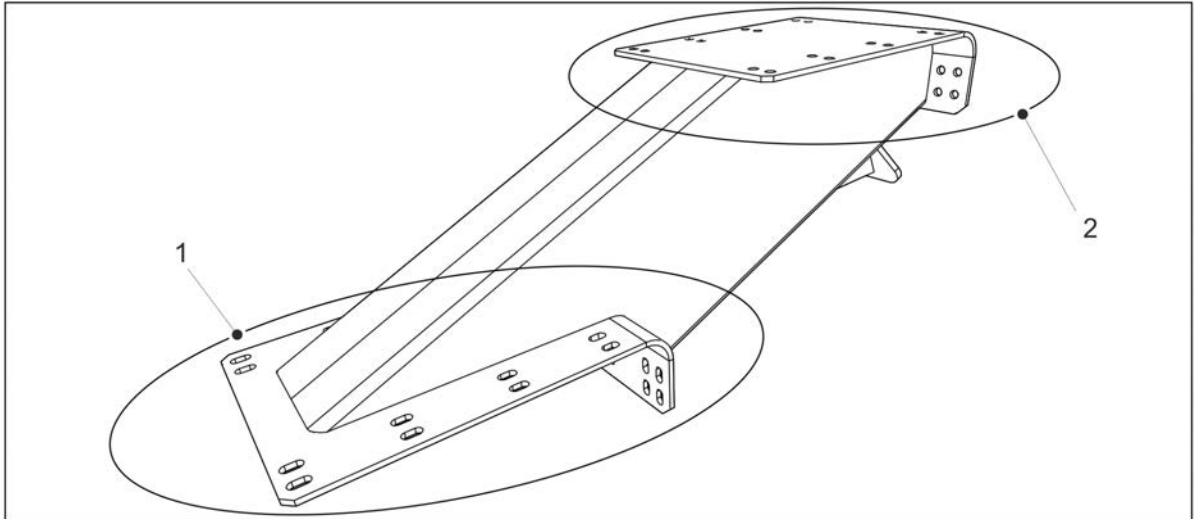

8.6.3 Daily maintenance

1. Check the tightness of the fastening bolts in areas (1) and (2).

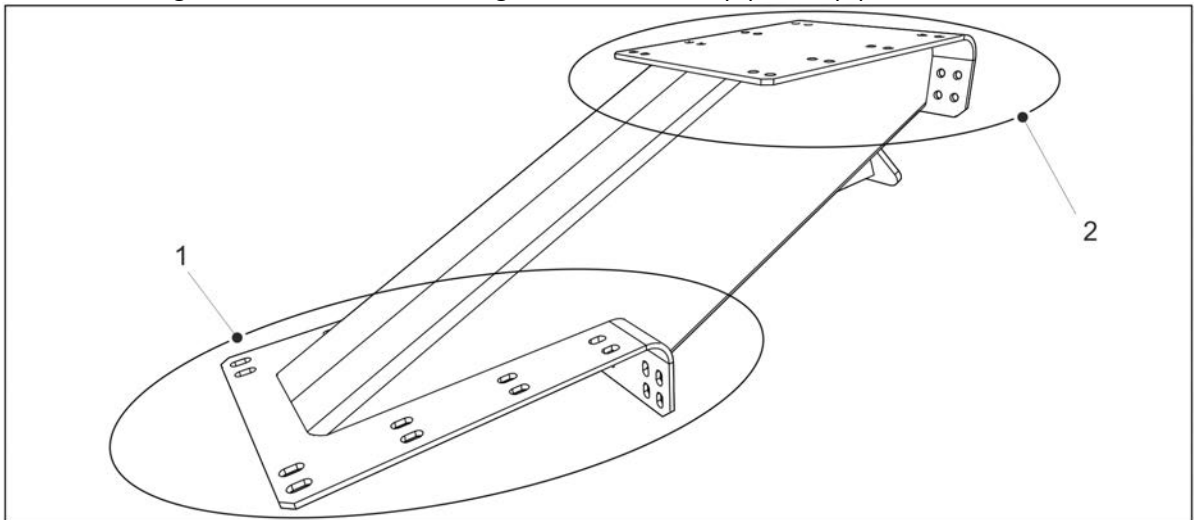

2. Visually check that there are no cracks or fractures on the foot.

9 ATTACHMENTS

Warranty

Warranty period is model and equipment specific, confirm the warranty period length from the reseller.

The warranty period starts on the date of purchase.

Warranty does not cover:

- Cutting blades and hydraulic hoses.
- Defects caused by wear or prohibited use. For prohibited and intended use of the equipment, read the instruction manual.
- Loss of earnings and other indirect costs from down time.
- Costs due to transporting the equipment to warranty repair.

Warranty is void if:

- Other than original parts are used on the tree shear.
- The owner of the tree shear changes during the warranty period.
- The tree shear is used in temperatures below -15 °Celsius.

Warranty repairs are performed at the facilities of the manufacturer or the retailer.

The warranty repair is carried out within a reasonable time, maximum of 4 weeks.

EU Declaration of Conformity



Manufacturer Name: JAK-Metalli Oy
Address: Voimankatu 3
35820 Mänttä
Phone: 040 080 4658
e-mail: info@jak.fi

JAK-Metalli Oy declares that the products manufactured by us are compliant with requirements of following European parliament and council directives:

- Machine Directive 2006/42/EU

The Declaration of Conformity covers the following products:

- JAK-400C
- JAK-300B, R and C
- JAK-250B, R and K
- JAK-200B, R and K
- JAK-220C
- JAK-220C, JAK-300C and JAK-400C Collector Units
- JAK-250R and B, JAK-300R and B Collector Units
- JAK-350 Guillotine Unit

Note! The declaration of conformity is not valid if the energy wood grapples mentioned before are used against laws, general safety instructions and this user instruction.

In the usage of the machine, situations may arise not mentioned in the user instructions. In these situations, we recommend to follow extreme caution. The manufacturer is not responsible for the use of the actions in these situations or for the damages happening in these situations.

The manufacturer is not responsible for the damages to the third party.

The manufacturer is not responsible for the damages that the JAK energy wood grapple has caused to machine or to the device.

The owner of the grapple is responsible for the correct functioning, use and maintenance of the grapple if not agreed in other ways separately.

The owner of the grapple is responsible, as well, for the case that all the persons using the machine have enough information about the handling and use of the grapple.

Instructions and technical file for machinery: Please contact to manufacturer

Mänttä 27.10.2023

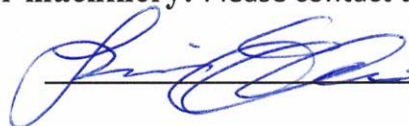

Jani Sipilä, Technical expert
